

# °CALEONbox

Heating circuit controller for surface heating systems



## Installation and operating instruction



**Read carefully before installation, commissioning and operation**

# CONTENT

<b>Safety Instructions</b> .....	<b>3</b>
EU-Conformity .....	3
General Instructions .....	3
Explanation of Symbols .....	3
Changes to the Unit .....	4
Warranty and Liability .....	4
Disposal and Pollutants .....	4
<b>Description °CALEONbox</b> .....	<b>4</b>
Description .....	4
Technical Data .....	5
Scope of Supply .....	6
<b>Installation</b> .....	<b>6</b>
Wall Installation .....	6
Electrical Connection .....	7
Electrical Terminals .....	8
LED status .....	9
Connection Examples Room Controller .....	10
Connection example single-family house with >8 zones .....	11
Connection example apartment building .....	12
Connection Examples 1-Wire Sensors .....	13
Compatibility and connection example °C-Lite .....	14
1-Wire ID overview .....	15
<b>Setup Wizard</b> .....	<b>16</b>
<b>Operation</b> .....	<b>16</b>
Room Overview .....	16
Operating Mode .....	17
Menu .....	17
Set Operation Hours .....	18
Set Operation Hours .....	18
Expert Menu .....	19
Settings .....	20
Devices .....	21
Rooms .....	22
Temperature/Humidity .....	23
Functions °Cbox .....	24
Zones .....	30
Example zone setting .....	31
WiFi .....	32
Service Values .....	33
°CALEON WiFi and App Configuration .....	33
<b>Tips</b> .....	<b>34</b>

# Safety Instructions

## EU-Conformity

By affixing the CE mark to the unit the manufacturer declares that the °CALEONbox conforms to the following relevant safety regulations:

- EU low voltage directive 2014/35/EU
- EU electromagnetic compatibility directive 2014/30/EU
- EU RoHS Directive 2011/65/EU
- EU WEEE Directive 2012/19/EU (Reg.nr. DE 23479719)

conforms. Conformity has been verified and the corresponding documentation and the EU declaration of conformity are kept on file by the manufacturer.

## General Instructions

### Please read carefully!

These installation and operating instructions contain basic instructions and important information regarding safety, installation, commissioning, maintenance and the optimal use of the unit. Therefore these instructions must be read and understood completely by the installation technician/specialist and by the system user before installation, commissioning and operation of the unit.

This unit is an automatic, electrical Heating circuit controller for surface heating systems for and similar applications. Install the unit only in dry areas and under the ambient conditions described in "Specifications".

The valid accident prevention regulations, VDE regulations, the regulations of the local power utility, the applicable DIN-EN standards and the installation and operating instruction of the additional system components must also be observed.

Under no circumstances does the unit replace any safety devices to be provided by the customer!

Installation, electrical connection, commissioning and maintenance of the device may only be carried out by an appropriately trained specialist. Users: Make sure that the specialist gives you detailed information on the function and operation of the unit. Always keep these instructions in the vicinity of the unit.

The manufacturer does not take over any liability for damage caused through improper usage or non-compliance of this manual!

## Explanation of Symbols



Danger

Failure to observe these instructions can result in electrocution.



Danger

Failure to observe these instructions can result in serious damage to health such as scalding or life-threatening injuries.



Caution

Failure to observe these instructions can result in destruction of the unit or the system, or environmental damage.



Caution

Information which is especially important for the function and optimal use of the unit and the system.

## Changes to the Unit

---

- Changes, additions to or conversion of the unit are not permitted without written permission from the manufacturer.
- It is likewise forbidden to install additional components that have not been tested together with the unit.
- If it becomes clear that safe operation of the unit is no longer possible, for example because of damage to the housing, turn the Unit off immediately.
- Any parts of the unit or accessories that are not in perfect condition must be exchanged immediately.
- Use only original spare parts and accessories from the manufacturer.
- Markings made on the unit at the factory must not be altered, removed or made illegible.
- Only the settings described in these instructions may be set using the Unit.



Changes to the unit can compromise the safety and function of the unit or the entire system.

## Warranty and Liability

---

The unit has been manufactured and tested with regard to high quality and safety requirements. The unit is subject to the statutory guarantee period of two years from the date of sale. The warranty and liability shall not include, however, any injury to persons or material damage that is attributable to one or more of the following causes:

- Failure to observe these installation and operating instructions.
- Improper installation, commissioning, maintenance and operation.
- Improperly executed repairs.
- Unauthorised structural changes to the unit.
- Use of the device for other than its intended purpose.
- Operation above or below the limit values listed in the 'Specifications' section.
- Force majeure.

## Disposal and Pollutants

---

The unit conforms to the European RoHS 2011/65/EU for the restriction of the use of certain hazardous substances in electrical and electronic equipment.



Under no circumstances may the device be disposed of with the normal household waste. Dispose of the unit only at appropriate collection points or ship it back to the seller or manufacturer.

## Description °CALEONbox

### Description

---

The °CALEONbox is a universal heating and individual room controller for surface heating systems. In combination with up to 8 °CALEON Room Controllers, this enables efficient use and function control of your surface heating with intuitive operation. The inputs and outputs can be freely assigned via °CALEON, so that different heating can be implemented.

Important characteristics of the °CALEONbox:

- Control of 8 heating zones with 1 - 4 actuators
- Measurement of room temperature and humidity in combination with °CALEON room controllers or 1-Wire Sensors
- optionally weather compensated via outdoor temperature sensor
- optional control of heating circuit pump and mixer (PWM oder 0-10V) possible
- 2 separate CAN bus interfaces for building network and private floor or apartment network
- connectable with other SOREL products via CAN-Bus
- Control of mixers, valves and energy generators via 0-10V / PWM
- 2 additional floating changeover contacts (terminals J and K) for flexible assignment
- optionally usable with standard room thermostats
- easy to install due to innovative strain relief and coloured terminal strip
- optional up to 20 1-Wire temperature sensors connectable

## Technical Data

Model	°CALEONbox	Heating circuit controller for surface heating systems
Temperature controller class (ErP)	8	
Energy efficiency (ErP)	5%	
Standby loss	0,5W	
Request type invertible heat pump	"On /off" and/or "modulating"	
<b>Electrical specifications:</b>		
Power Supply		230 VAC (+/- 5%), 50 - 60 Hz
Power consumption / standby		0,5 - 2,5W/ 0,5W
Internal fuse 1	1	(Pos A, left) 2A slow blow 250V Fuse protection for terminal area A and electronics
Internal fuse 2	1	(Pos B, right) 4A slow blow 250V Fuse protection for terminal area B - I
Protection Class		IP30
Protection class / overvoltage category		II / II
<b>Inputs</b>	Quantity	Measuring range / design
1-Wire temperature sensor parasitic	≤ 20 pices	-55 °C ... 125 °C (2 pole version)
1-Wire temperature sensor powered	> 20 pices	-55 °C ... 125 °C (3 pole version)
<b>Outputs</b>		
Switching relay outputs	11	
Relay heat pump	1	230 VAC, 2A, (AC1 920 VA, AC3 185W)
Relay actuator	8	230 VAC, 4A, (AC1 920 VA, AC3 185W)
Relay additional function	2	Potential-free max. 4A
PWM output	1	for 10 kΩ working resistance 1 kHz, level 10 V
0-10V output	1	
0-10V / PWM	1 (switchable)	
+ Voltage outputs 24VDC	3	Total max. 12 W for external devices e.g. °CALEON Room Controller
<b>Interface</b>		
Fieldbus	2 x	CAN bus (separate building CAN bus and private CAN bus)
<b>Max. Cable Length</b>		
1-Wire Sensors		up to 50 m parasitic, up to 100 m powered, use twisted pair cable
CAN		<3m; at> = 3m, a shielded twisted pair cable must be used. Isolate shielding and connect it to the protective conductor of <b>only one</b> of the devices. Max. cable length of the complete system 200 m.
0-10V/PWM		<3m
24 VDC		<30m
mechanical relay		<30m
<b>Permissible Ambient Conditions</b>		
during operation		0 °C - 40 °C, max. 85 % rel. humidity at 25 °C
for transport/storage		0 °C - 60 °C, no moisture condensation permitted
<b>Other Specifications and Dimensions</b>		
Housing Design		multi-part ABS
Installation Methods		DIN rail mounting or wall mounting on DIN rail
Overall dimensions		95 mm x 303 mm x 57 mm
Light diode		14 x LED green
Real Time Clock		RTC with 24 hour power reserve
Operation		via °CALEON Room Controller

## Scope of Supply

- Heating circuit controller for surface heating systems °CALEONbox
- Replacement fuse
- additional separation wall for use of non-230V AC actuators
- DIN rail H=35mm L=280mm 2 screws 3,5 x 35 mm and 2 dowels S6
- °CALEONbox installation and operating instructions

## Installation

### Wall Installation



Fix the DIN rail horizontally to the wall using screws.



#### Installation

1. Place the °CALEONbox on the upper edge of the DIN rail with the locking catch on top.

2 Engage the device by pressing it down. Ensure that the locking catches engage completely and that the device is firmly seated on the rail.

#### Disassembly

Remove the °CALEONbox from the DIN rail by inserting two screwdrivers into the eyelets and pulling them downwards.

### Separation walls and cover

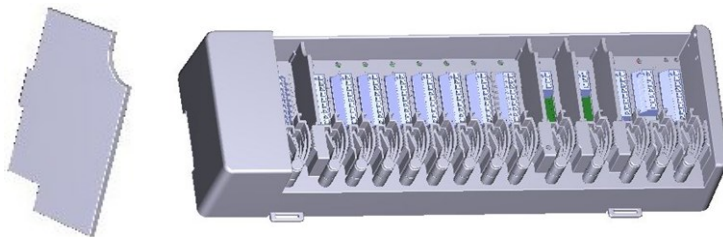

The separation walls and the cover can be removed for easier connection of the cables. They must then be reinstalled in order to safely separate areas carrying mains voltage from areas carrying low voltages.

Open the cover (90° degree) and then pull it out of the side of the attachment.



If the terminal blocks (B-I) are to be supplied with a voltage other than the mains voltage, proceed as follows:

1. Remove existing bridges A1 - B1 and A2 - B2
2. It is absolutely necessary to insert a separating wall between A - B.
3. Connect the power supply to B1 (L) and B2 (N).
4. Observe max. switching power of relay and fuse (4AT)

### Heating zones with 230 VAC actuators (bridge)

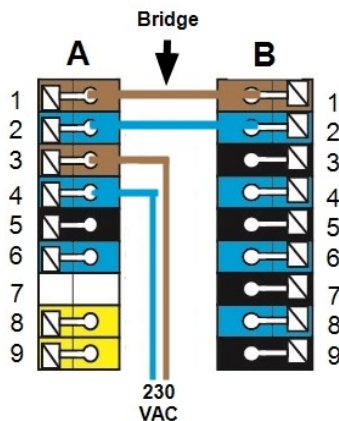

### Heating zones with e.g. 24 VAC actuators (separation wall)

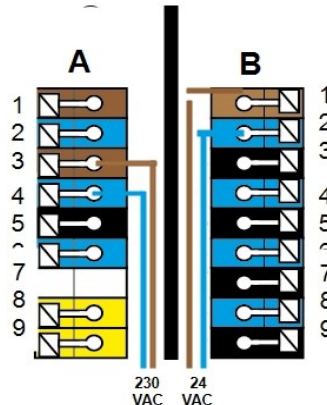

## Electrical Connection



Low-voltage cables such as temperature sensor cables must be routed separately from mains voltage cables.



Before working on the unit, switch off the power supply and secure it against being switched on again! Check that there is no power flowing! Electrical connections may only be made by a specialist and in compliance with the applicable regulations. The unit may not be put into operation if there is visible damage to the housing, e.g. cracks.



The customer must provide an all-pole disconnecting device, e.g. an emergency heating switch.

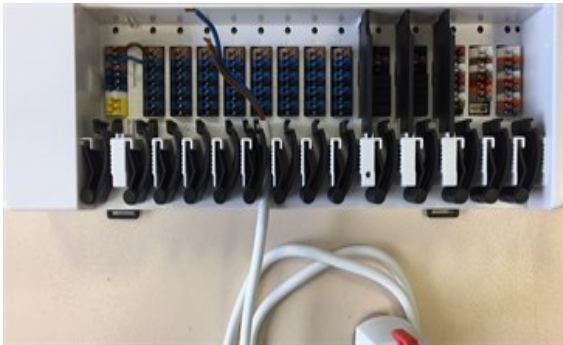

The strain reliefs are suitable for flexible cables with a cable sheath diameter of 5 mm to 8 mm, primarily using the lower strain relief (as shown). The cables must be checked for firm placement. Solid, thicker and thinner cables must always be laid firmly and must be fixed on the installation side.

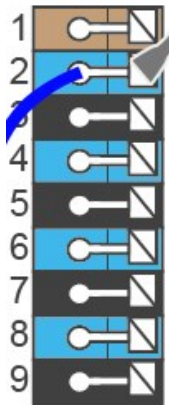
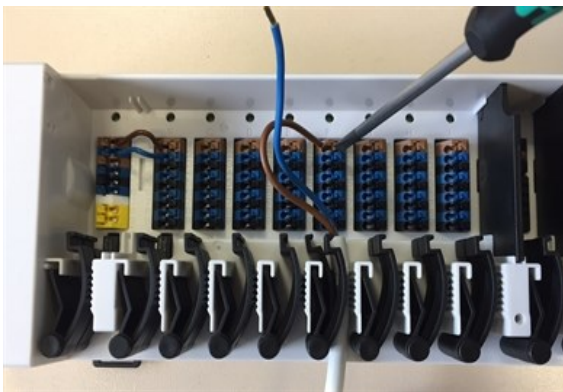

Massive wires or cables with special wire end sleeves can simply be pressed into the terminals. For other wires, the trowel must first be **completely pressed on** with a screwdriver as shown.



Wire ferrules made of brass can be difficult to clamp due to their asymmetric crimping shape. In this case, remove the wire ferrule. The plug-in terminals are also suitable for flexible cables.

# Electrical Terminals

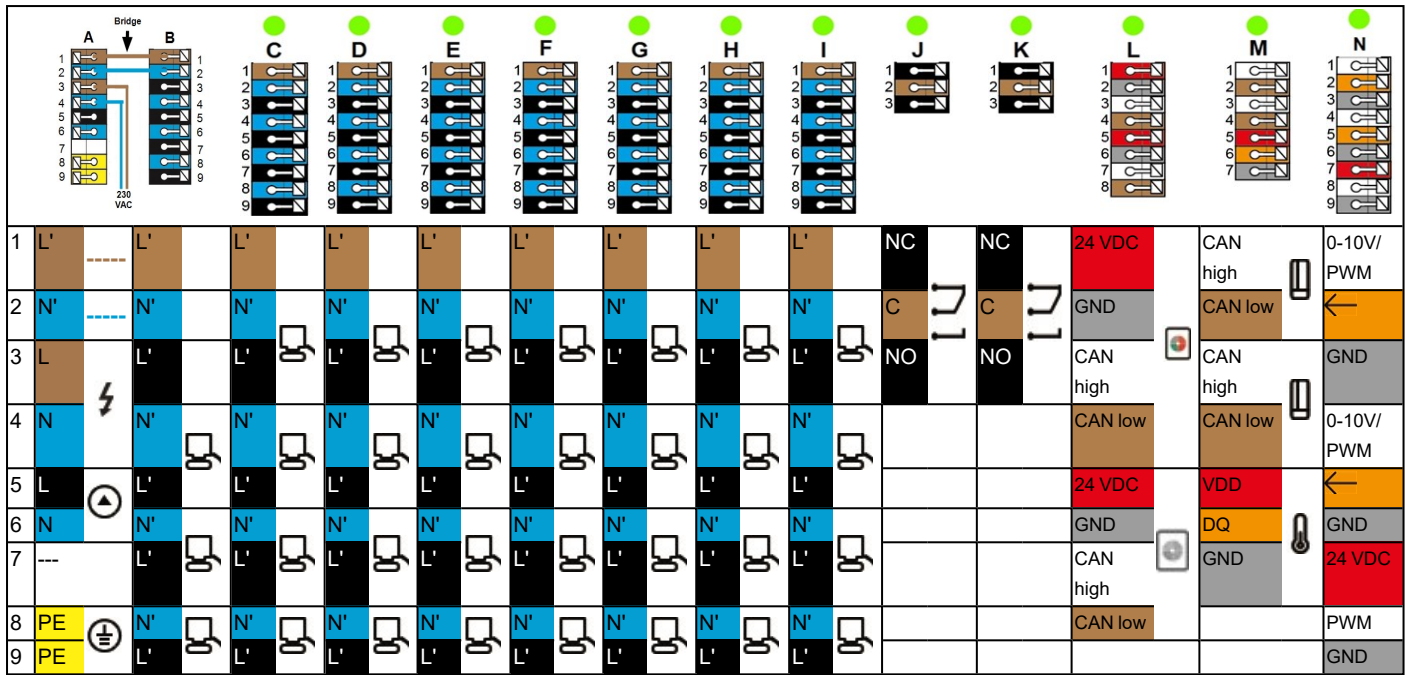

## Example Wiring of Terminal Blocks

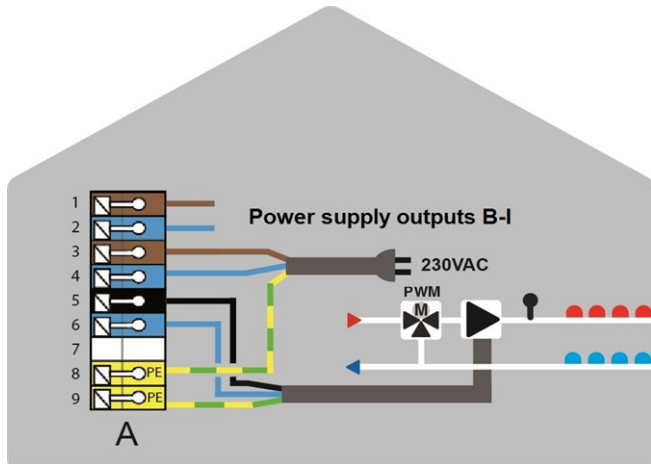

Mains connection heating circuit pump

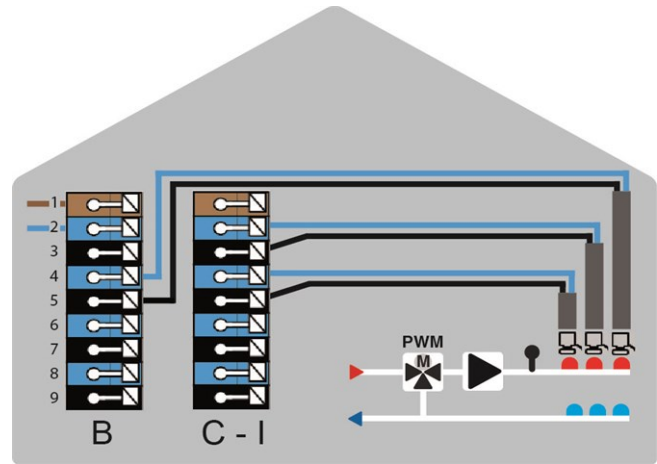

Actuators for the heating zones

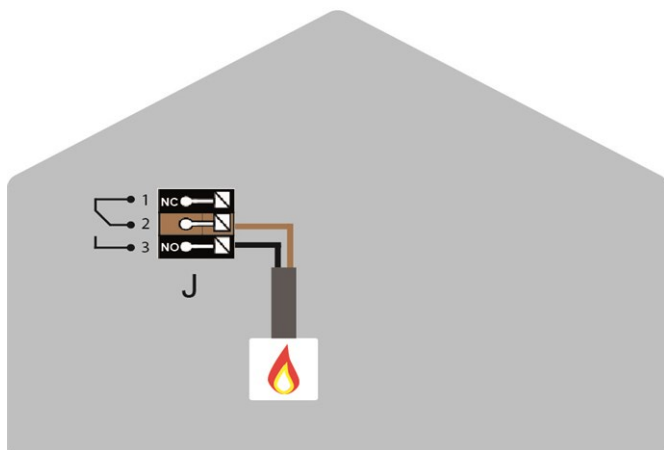

Potential-free switching contacts for additional functions

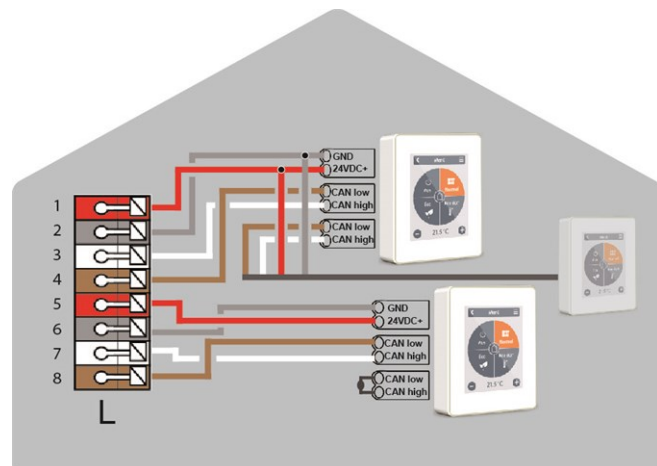

°CALEON Room Controller in private CAN bus

### Private CAN bus

For linking devices within a housing unit, such as a single-family house or a flat. Shares all information with all devices in the same network, including room names, setpoint temperatures, absences, etc.

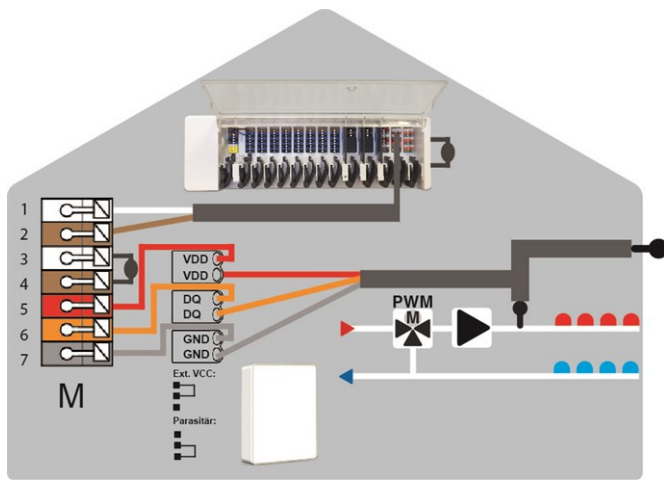

**Building CAN bus and 1-Wire sensors**

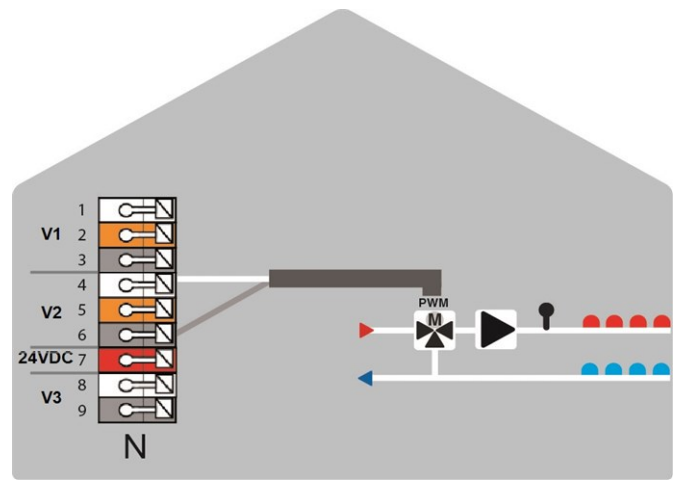

**0-10V/PWM outputs for additional functions**

### Building CAN bus

For linking devices across several units, such as flats, offices or hotel rooms. Only shares information relevant for optimising the overall system:

- Outdoor temperature
- Energy demand
- Flow temperature
- Season (heating / cooling)

### LED status

LED A	Lights up if mains voltage is present and relay A is switched
LED B - K	Lights up, if relay B - K is switched.
LED L	Flashes, if the private CAN bus is active. Flashes at 1Hz (60x / minute) if there is an error in the private CAN bus.
LED M	Lights up when the building CAN bus and the 1-wire bus are active. Flashes at 1Hz (60x / minute) if there is an error in the building CAN bus. Flashes at 3Hz (180x / minute) if there is an error in the 1-wire connection. <b>EXCEPTION:</b> If the building CAN bus remains unused, a flashing of the LED M is normal and does <b>NOT</b> mean that there is an error.
LED N	Lights up, if outputs V1, V2 or V3 are active.

## Connection Examples Room Controller



Do not combine devices for heating only (°CALEON/ °CALEONbox) with devices for heating and cooling (°CALEON Clima/°CALEONbox Clima).

### Example 1: Tree Structure

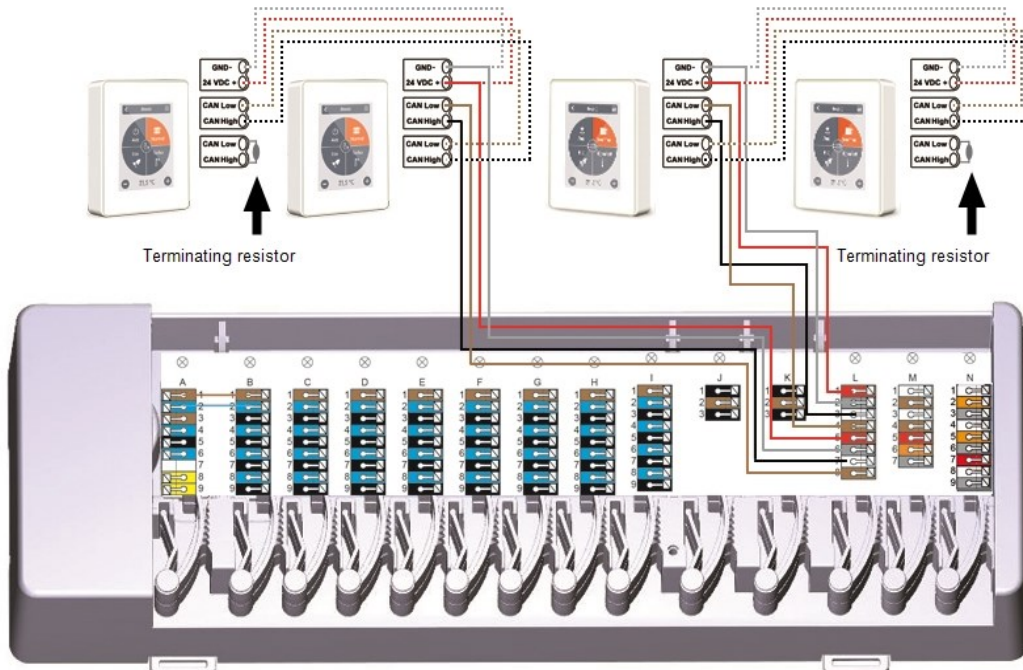

A 120 Ohm terminating resistor must be set on the first and last device in the CAN network.

### Example 2: Line

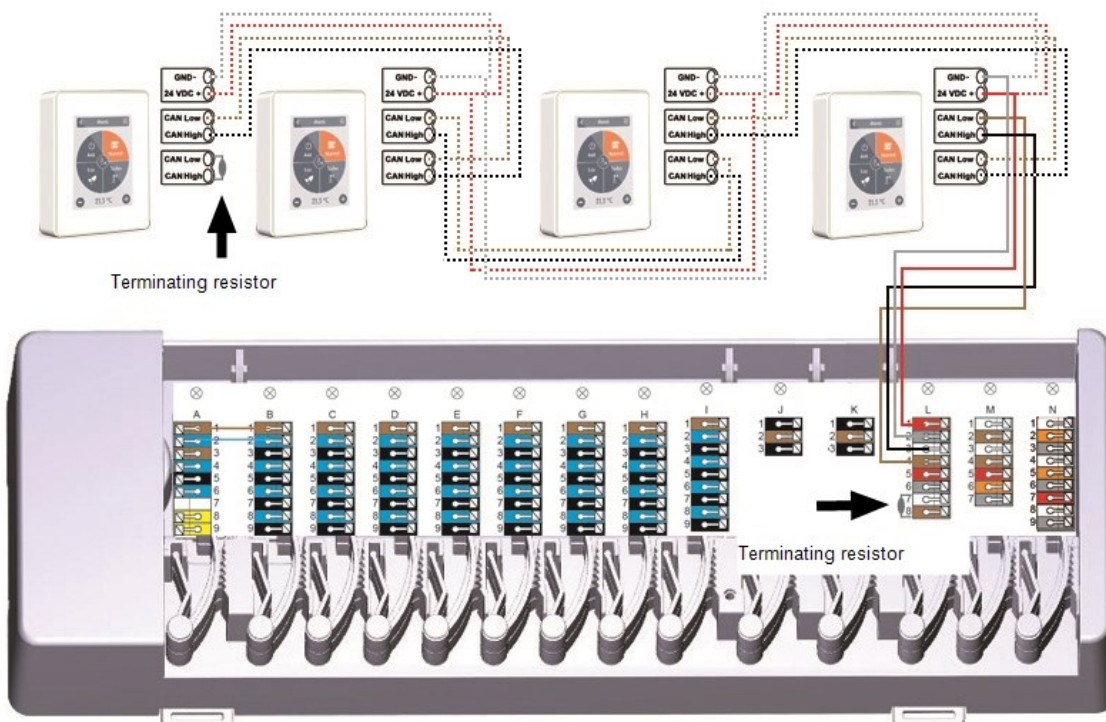

A 120 Ohm terminating resistor must be set on the first and last device in the CAN network.

## Connection example single-family house with >8 zones

Example: 2 °CALEONboxes connected

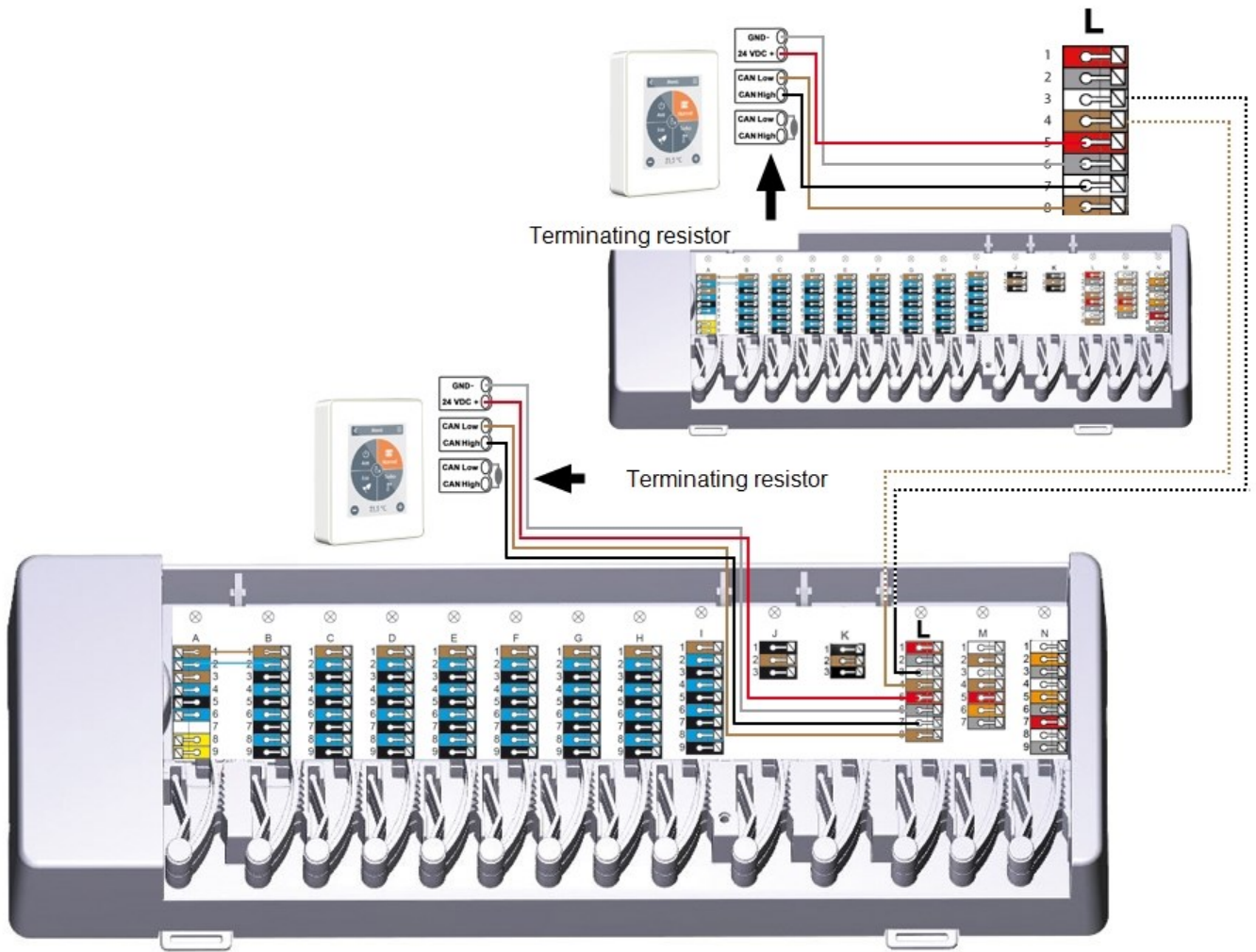

A 120 Ohm terminating resistor must be set on the first and last device in the CAN network.

## Connection example apartment building

Example: °CALEONboxes connected with LHCC controller

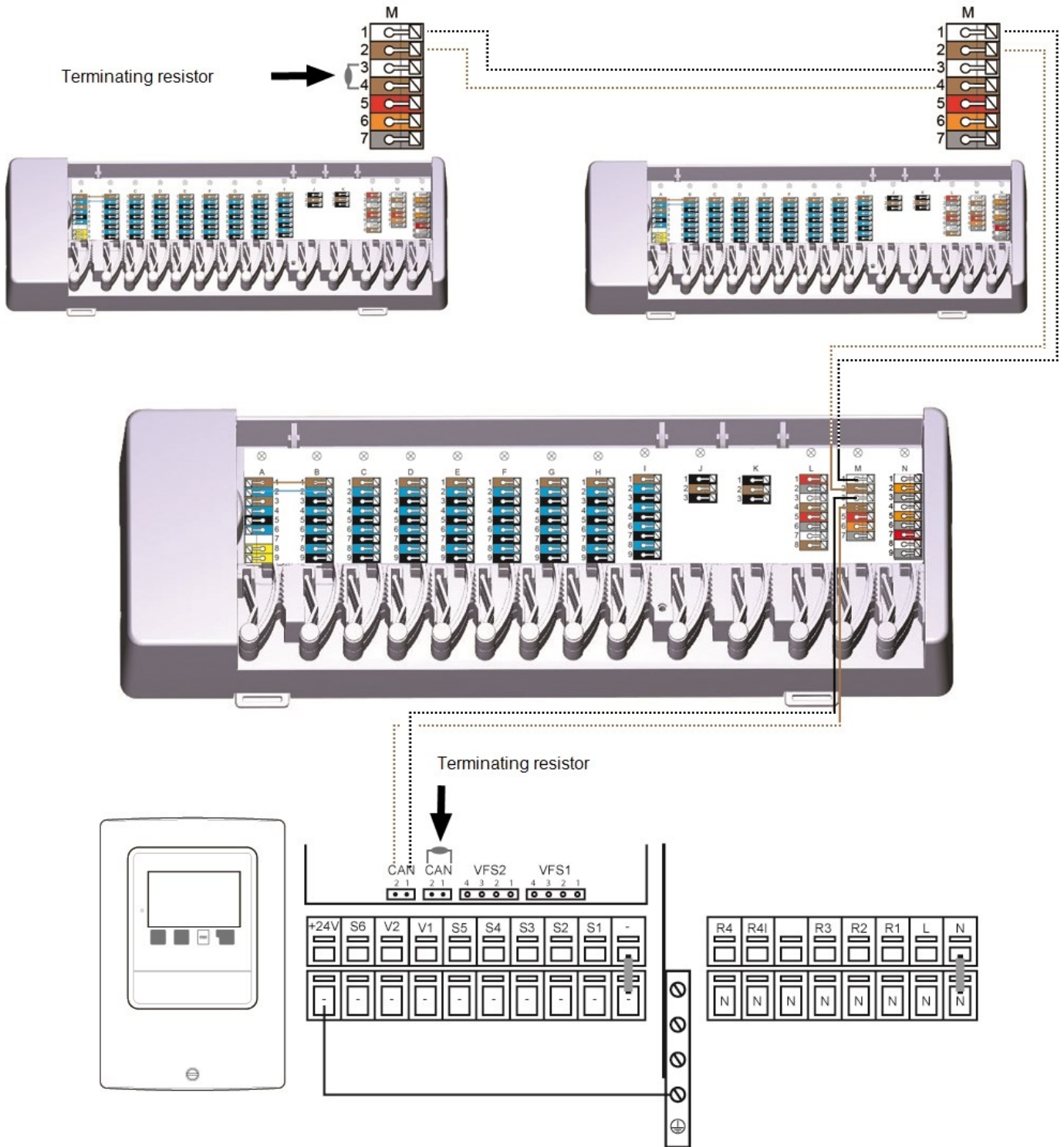

Use **building CAN bus** on **terminal block M** so that no private data such as room temperatures or holiday mode are shared across flats.



A 120 Ohm terminating resistor must be set on the first and last device in the CAN network.

## Connection Examples 1-Wire Sensors



When connecting the 1-Wire sensors, please record the 16-digit 1-Wire ID and the location of the sensor for later commissioning of the system! The 1-Wire ID can be found in the device housing and in the device menu under: Devices -> °CALEONbox -> Resources -> 1-Wire sensor.

**Example 1: Line.** The installation leads from one sensor to the next. A twisted pair cable must be used for the connecting cable.

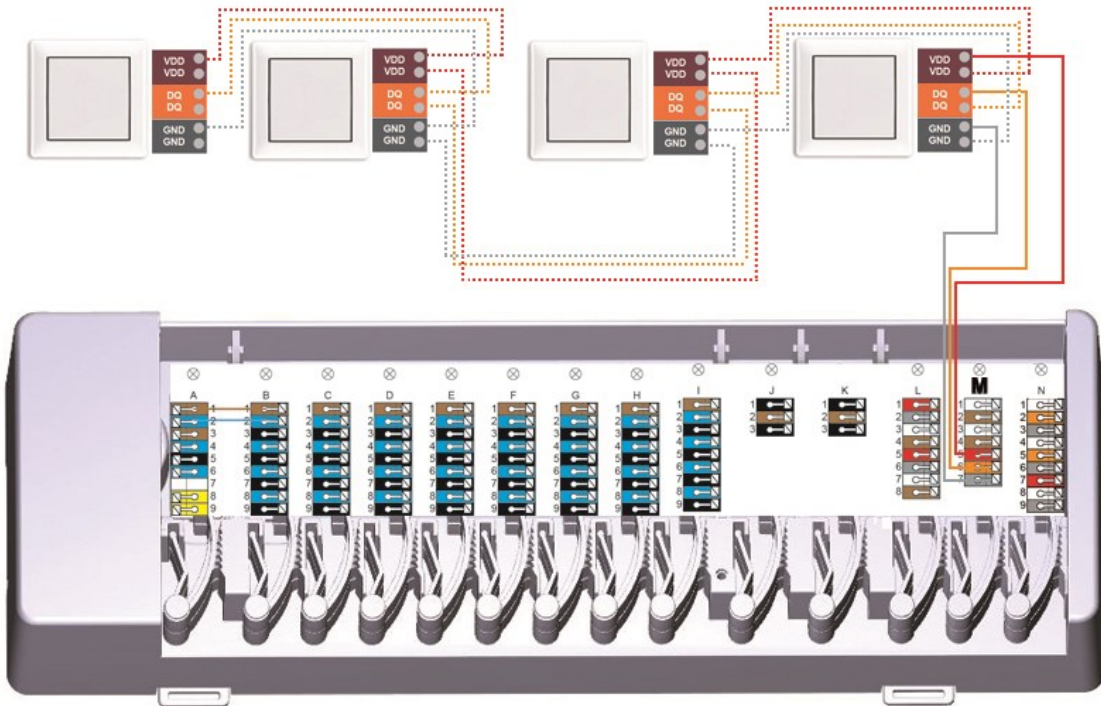

**Example 2: Tree Structure.** A twisted pair cable must be used for the connecting cable.

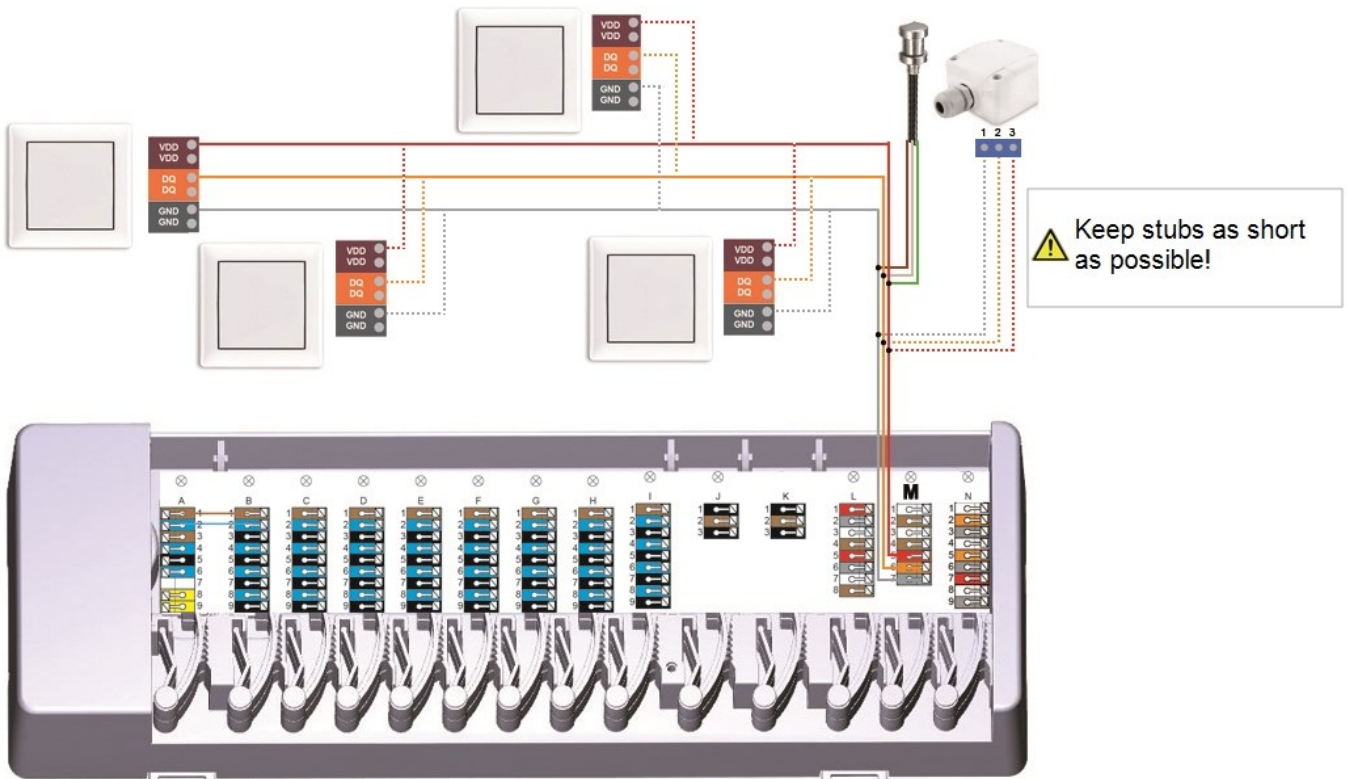

## Compatibility and connection example °C-Lite

The following must be observed when connecting °C-Lite with the °CALEONbox:

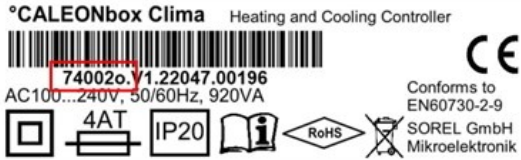

- **Art. No. until .....n**  
no °C-Lite via 5V DC, external power supply and software update required
- **Art. No. from .....o**  
1 °C-Lite via 5V DC, external power supply unit and software update required for others
- **Art. No. from .....p**  
up to 8 °C-Lite can be connected

**Example line:** The installation leads from one sensor to the next. A twisted pair cable must be used for the connecting cable.

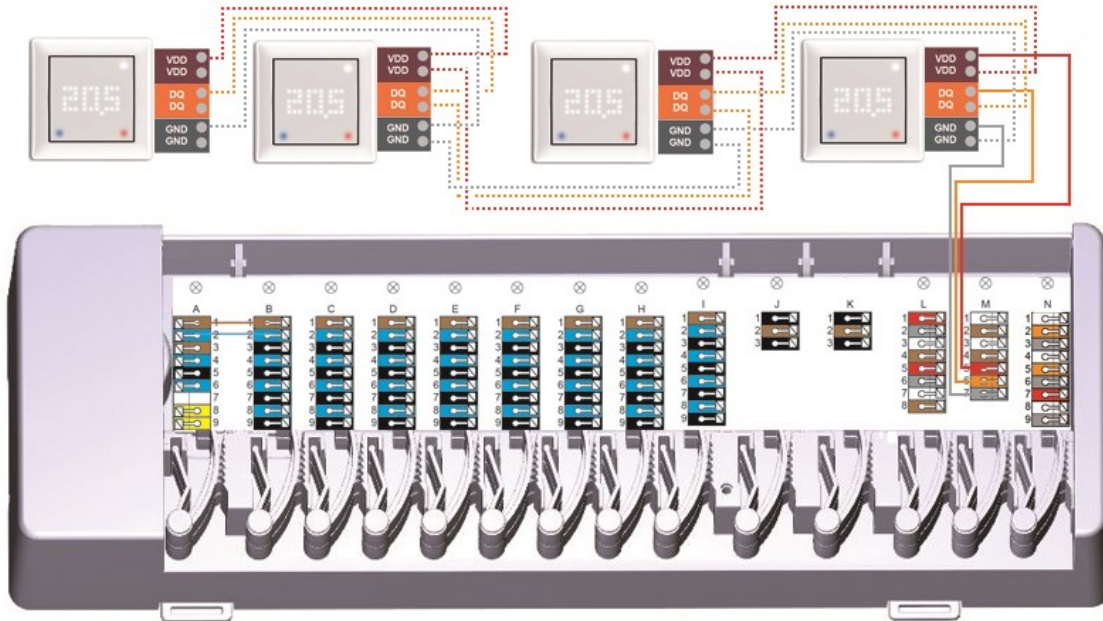

# 1-Wire ID overview

For systems with 1-Wire sensors, you must assign the respective 1-Wire ID to a room on the °CALEON Room Controller. Writing down the IDs in combination with the room in which the sensor hangs in the following list simplifies the later assignment.





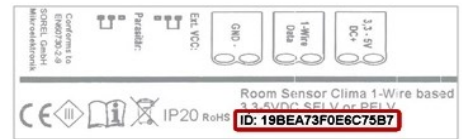

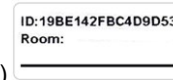

The 1-Wire ID can be found inside the sensor on the type plate (1) and on the supplied sticker (2). We recommend to insert the sticker into the following table.

(1)



(2)



1-Wire Room Sensor		
1-Wire Room Sensor flush-mounted		
1-Wire Pipe Sensor 1-Wire Floor Sensor		
1-Wire Outdoor Sensor		

	Location	1-Wire ID		Location	1-Wire ID
Example	Bathroom	1053f67c0308009e	11		
1			12		
2			13		
3			14		
4			15		
5			16		
6			17		
7			18		
8			19		
9			20		
10			21		

## Setup Wizard

The setup wizard in the °CALEON Room Controller starts automatically when the device is commissioned for the first time and guides you through the necessary basic settings in the correct sequence. Press the arrow keys in the upper right/left corner to return to the next or previous setting.



Commissioning must also be completed on all other °CALEON Room Controllers in the network.



The °CALEONbox is configured **exclusively** on a °CALEON Room Controller.



The setup wizard is restarted via the "Factory settings" menu item.

## Operation

To configure the °CALEONbox, you need at least one °CALEON Room Controller. This is connected to the °CALEONbox through the private CAN bus as described before (see "Electrical Connection" on page 7).

### Room Overview

Displays the room temperature, humidity and external temperature once the start screen was activated.

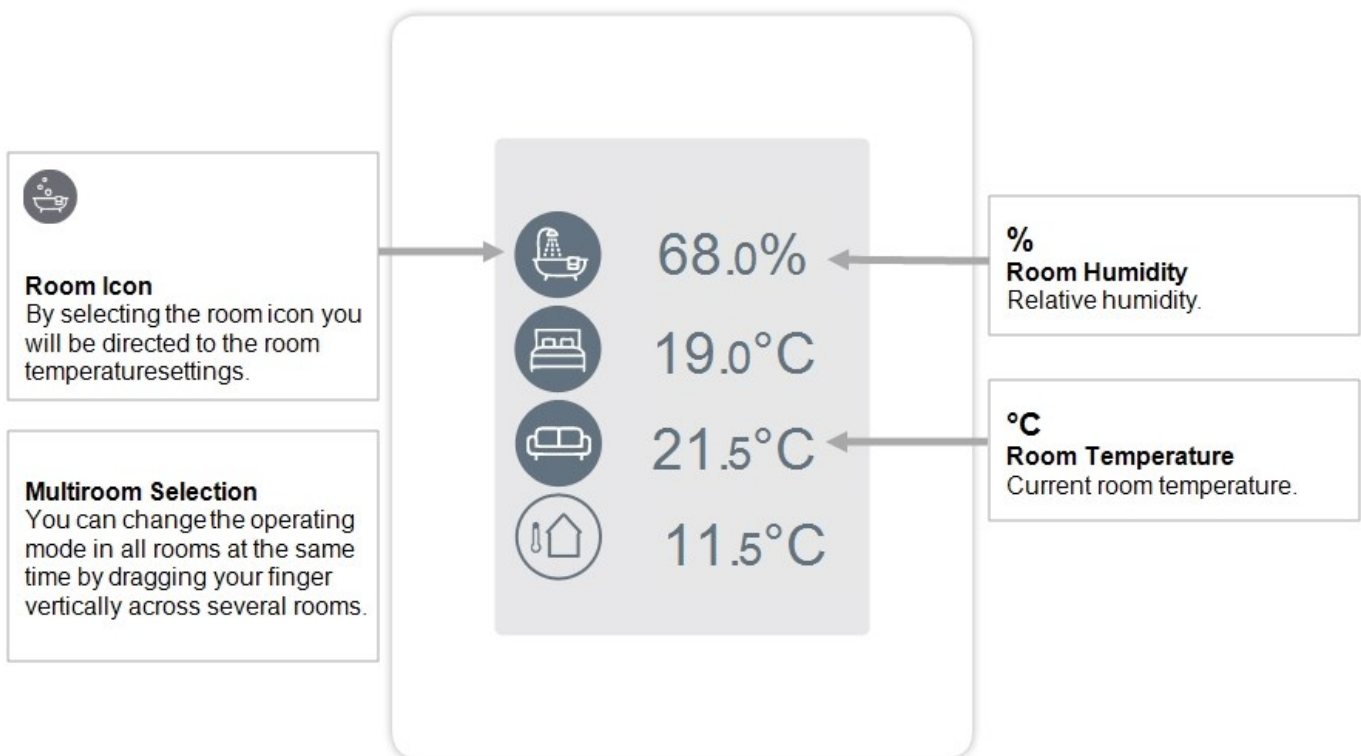

# Operating Mode

Overview > Operating Mode

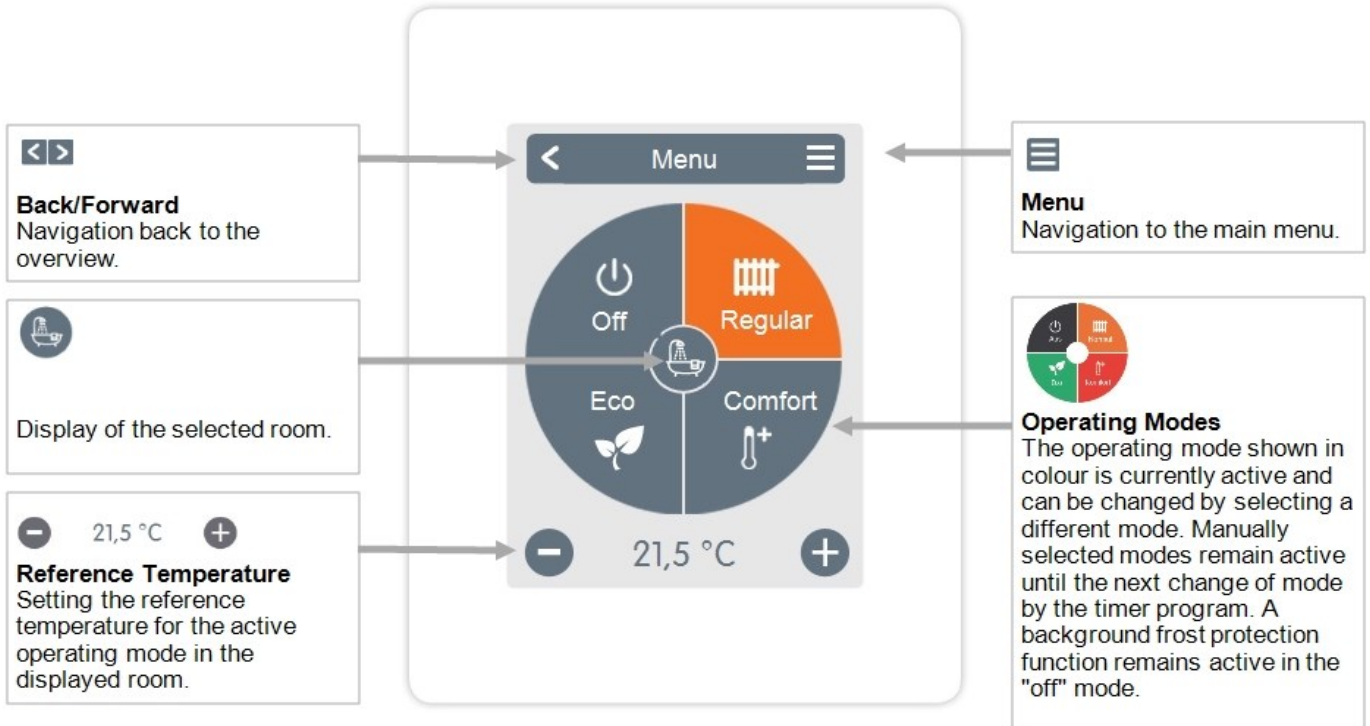

# Menu

Overview > Operating Mode > Menu

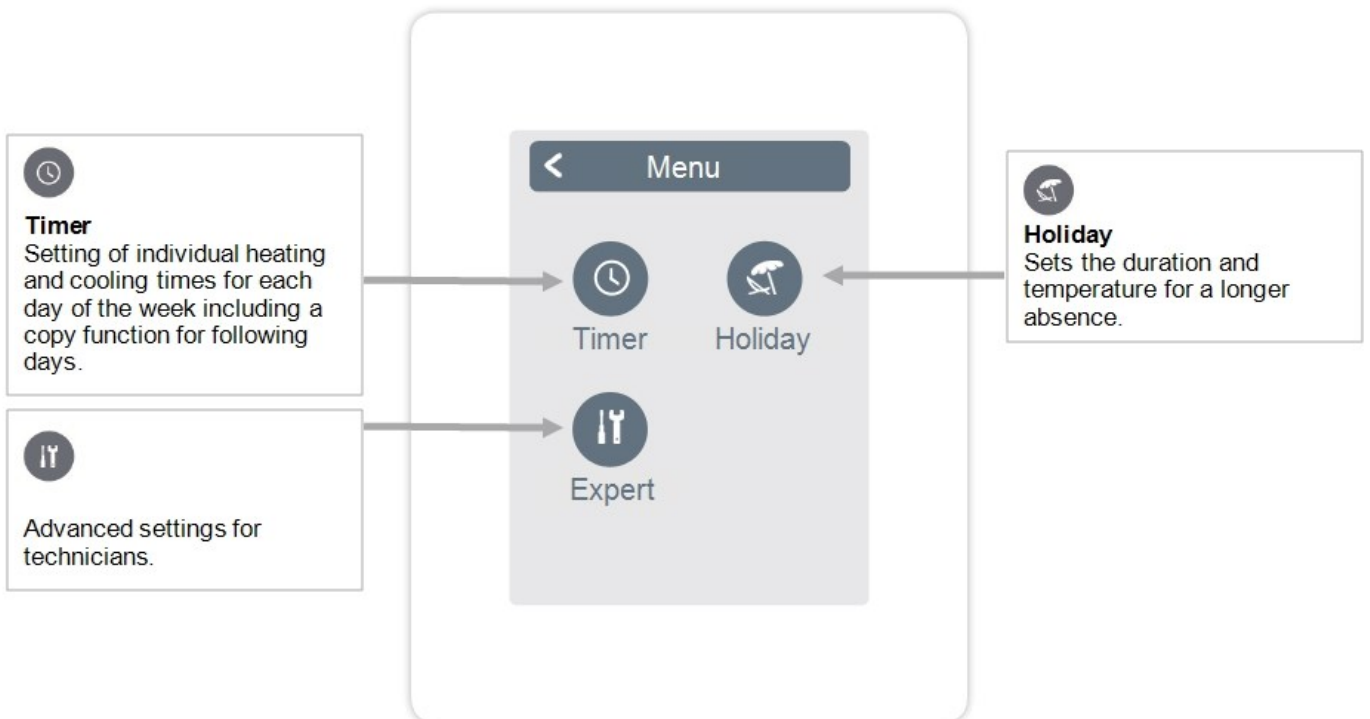

## Set Operation Hours

Overview > Operating Mode > Menu > Timer

Setting of individual heating and cooling times for the selected room.

**Operating Modes**  
Selection of the operating mode to select individual heating sections.

**Clock**  
Time table for selecting the time intervals in 30-minute steps. Touch individual segments, or drag your finger over complete time intervals to colour them according to the selected operation mode.

**Menu**  
Opens the copy function. This function allows you to copy the heating times for the next day, on Monday-Friday or Monday-Sunday.

**Back/Next Weekday**  
Selection of the day of week which is to be set.

## Set Operation Hours

**Schritt 1** Use the arrow keys to select the desired day.

**Step 2**  
Select the first heating mode (Normal) - with the index finger select the desired length of time. The selected period will be coloured after selecting the colour of the operating mode (normal = orange). Set the times of the other operating modes in the same way.

**Step 3**  
After completing the setting of the individual heating and cooling times, you have the option of copying the times via the main menu to the following day, to Monday - Friday or to Monday - Sunday or individually for each weekday.

**! In the interests of efficient and energy-saving single room control, the operating times should be set specifically for each room.**

**! When setting the operating times, please consider that surface heating systems are inherently inert.**

# Expert Menu

Overview > Operating Mode > Menu > Expert

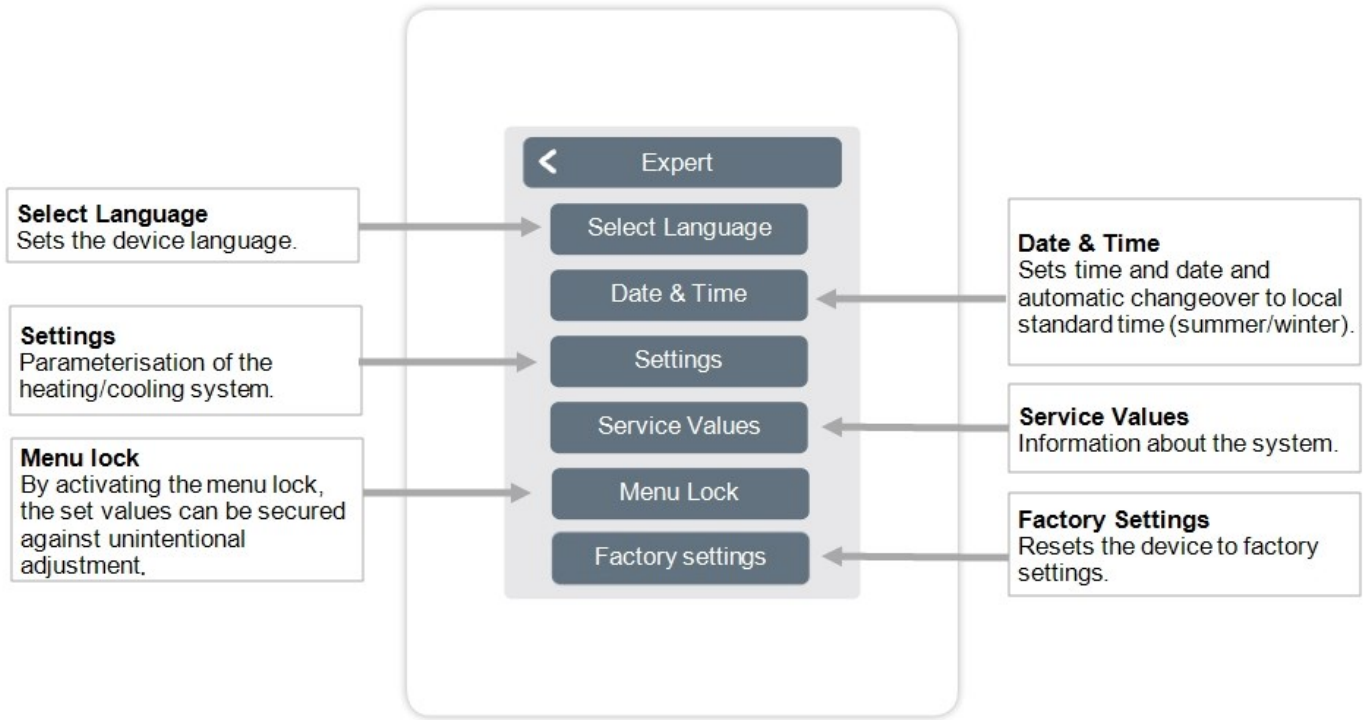

 The menu structure described here is based on the status at the time of production and may vary due to subsequent software changes.

## Settings

Overview > Operating Mode > Menu > Expert > Settings

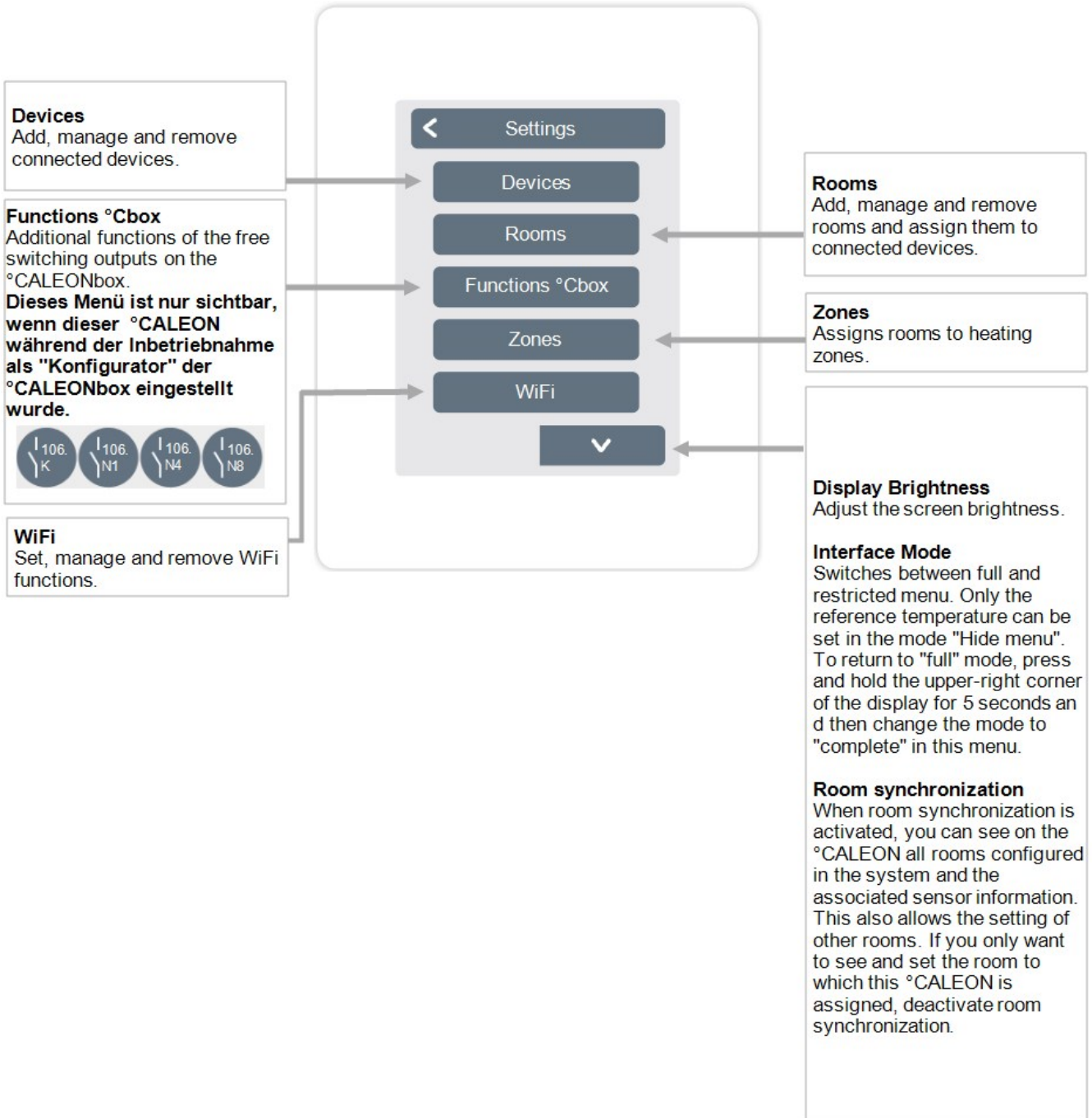

# Devices

Overview > Operating mode > Menu > Expert > Settings > Devices



Do not combine devices for heating only (°CALEON/ °CALEONbox) with devices for heating and cooling (°CALEON Clima/°CALEONbox Clima).

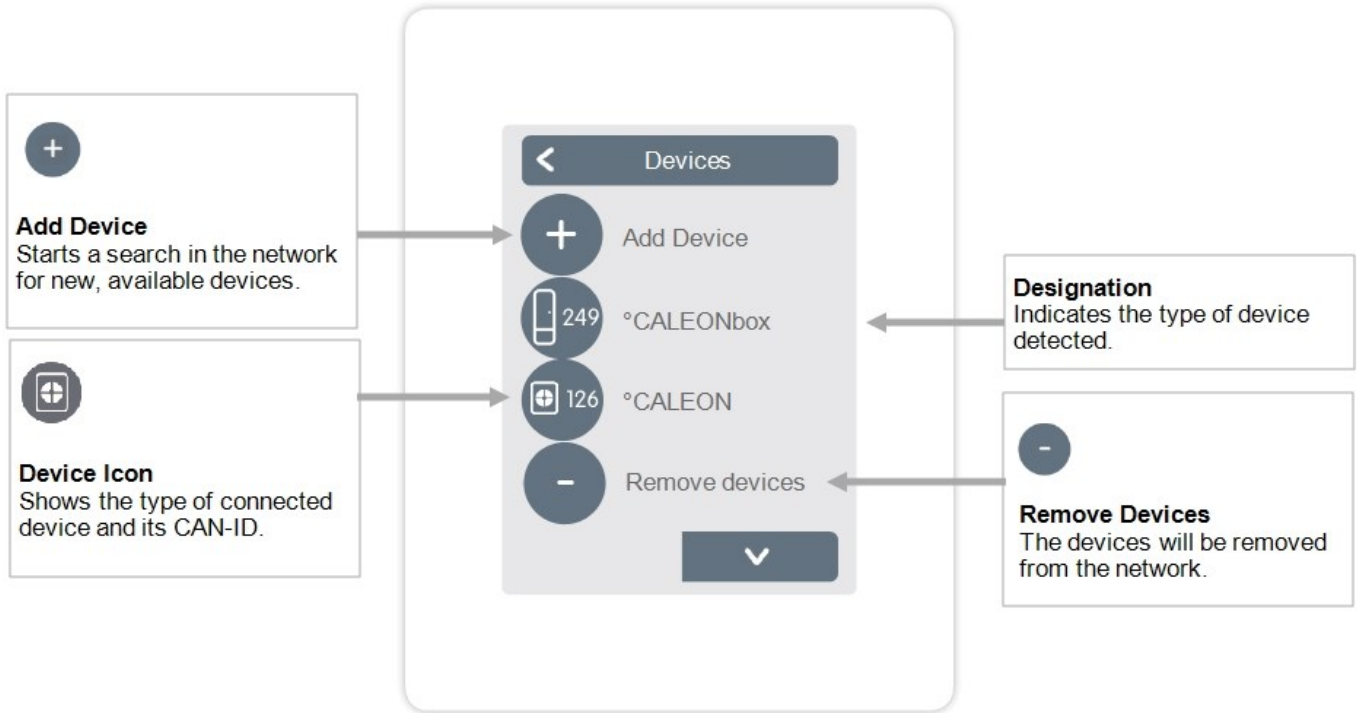

Overview > Operating mode > Menu > Expert > Settings > Devices > °CALEONbox

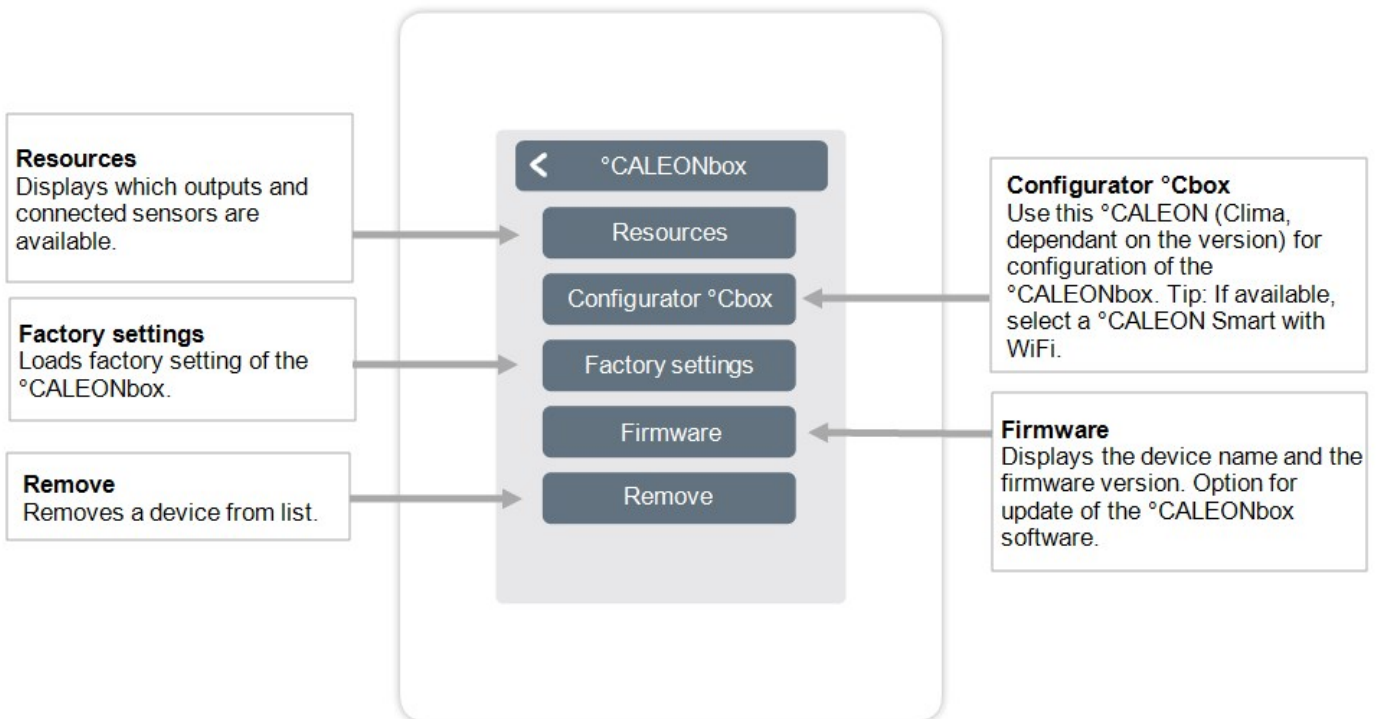

# Rooms

Overview > Operating mode > Menu > Expert > Settings > Rooms

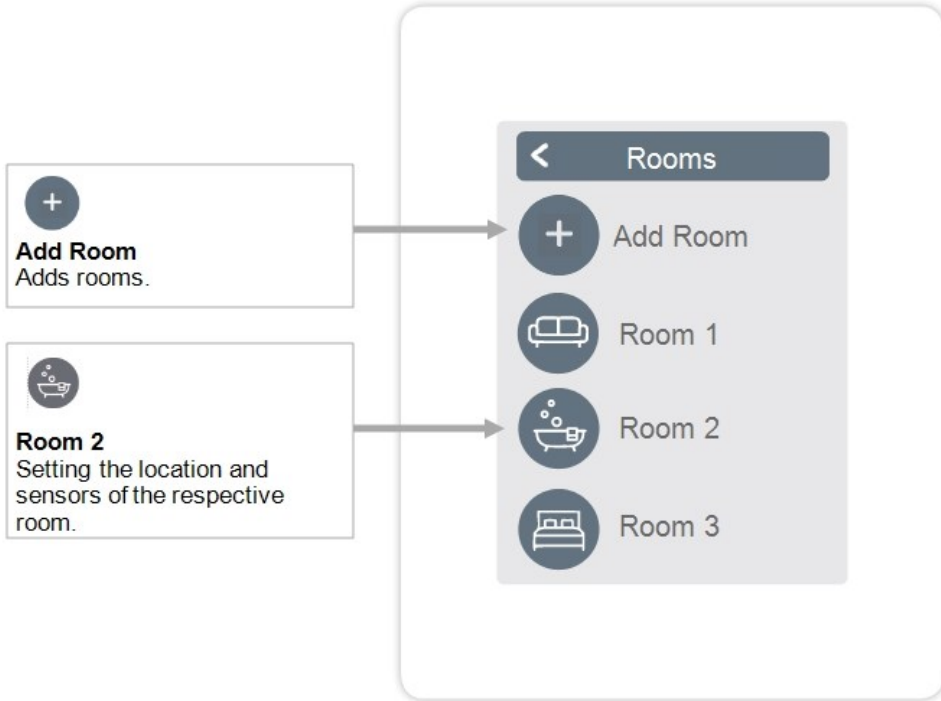

Overview > Operating mode > Menu > Expert > Settings > Room 2

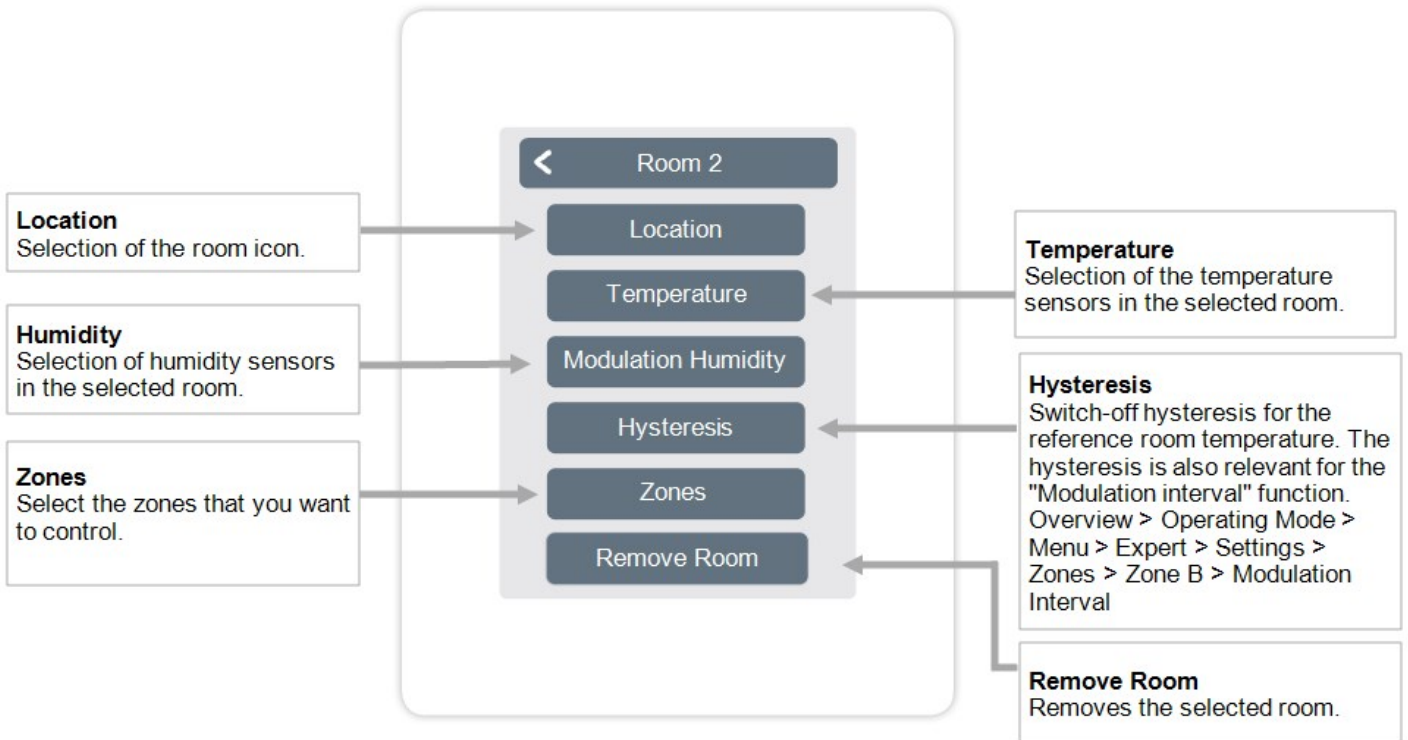

## Temperature/Humidity

Overview > Operating mode > Menu > Expert > Settings > Rooms > Room 1 > Temperature

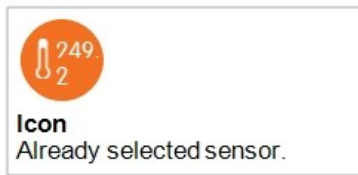

### < Temperature

- °CALEON  
23,5°C
- 238fad170a0000dc  
22,5°C
- 19be010274093094  
20,5°C
-

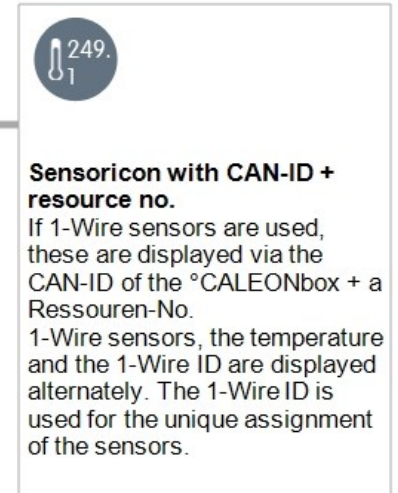

Overview > Operating mode > Menu > Expert > Settings > Rooms > Room 1 > Humidity

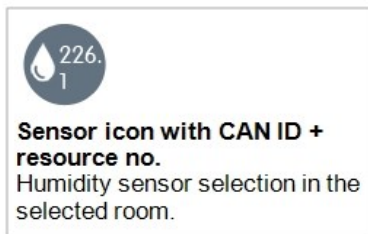

### < Modulation

- °CALEON  
47,3%
- 19be010274093094  
38,0%
-

## Functions °Cbox

Overview > Operating mode > Menu > Expert > Settings > Functions °Cbox

Activating and setting of additional functions on the free outputs of the °CALEONbox.

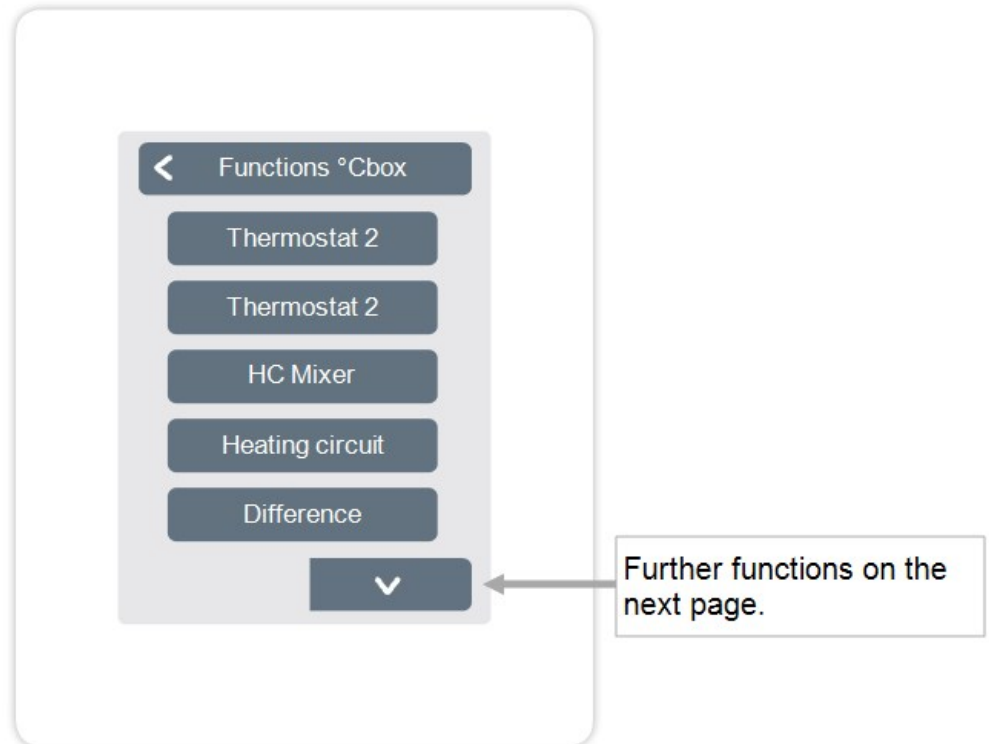

Further functions on the next page.

Overview > Operating mode > Menu > Expert > Settings > Functions °Cbox > Thermostat 2

Switches the defined output to the set room / rooms depending on time and temperature.

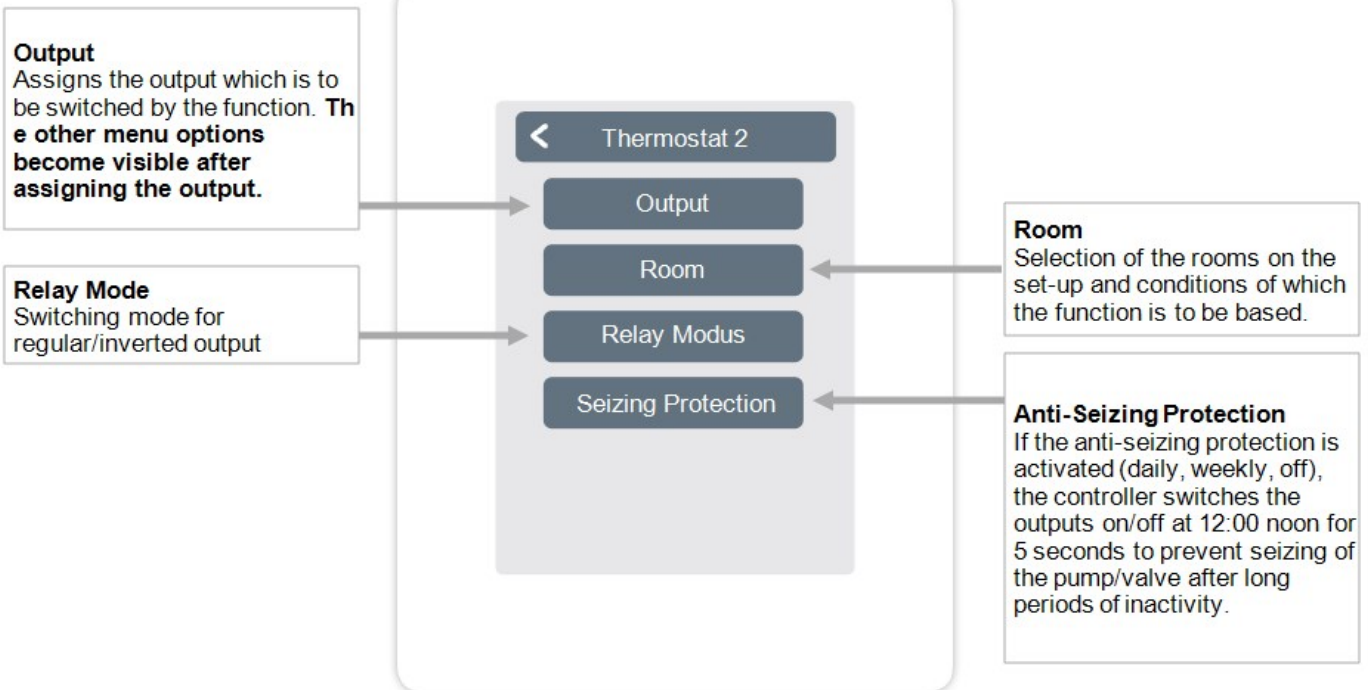

**!** In heating mode, the thermostat function switches on in at least one of the selected rooms when the room temperature falls below the target room temperature. The automatic summer switch-off of the zones via the outdoor temperature is not considered here.

The heating circuit mixer function controls the flow temperature via a 0-10V / PWM mixer depending on the outdoor temperature.

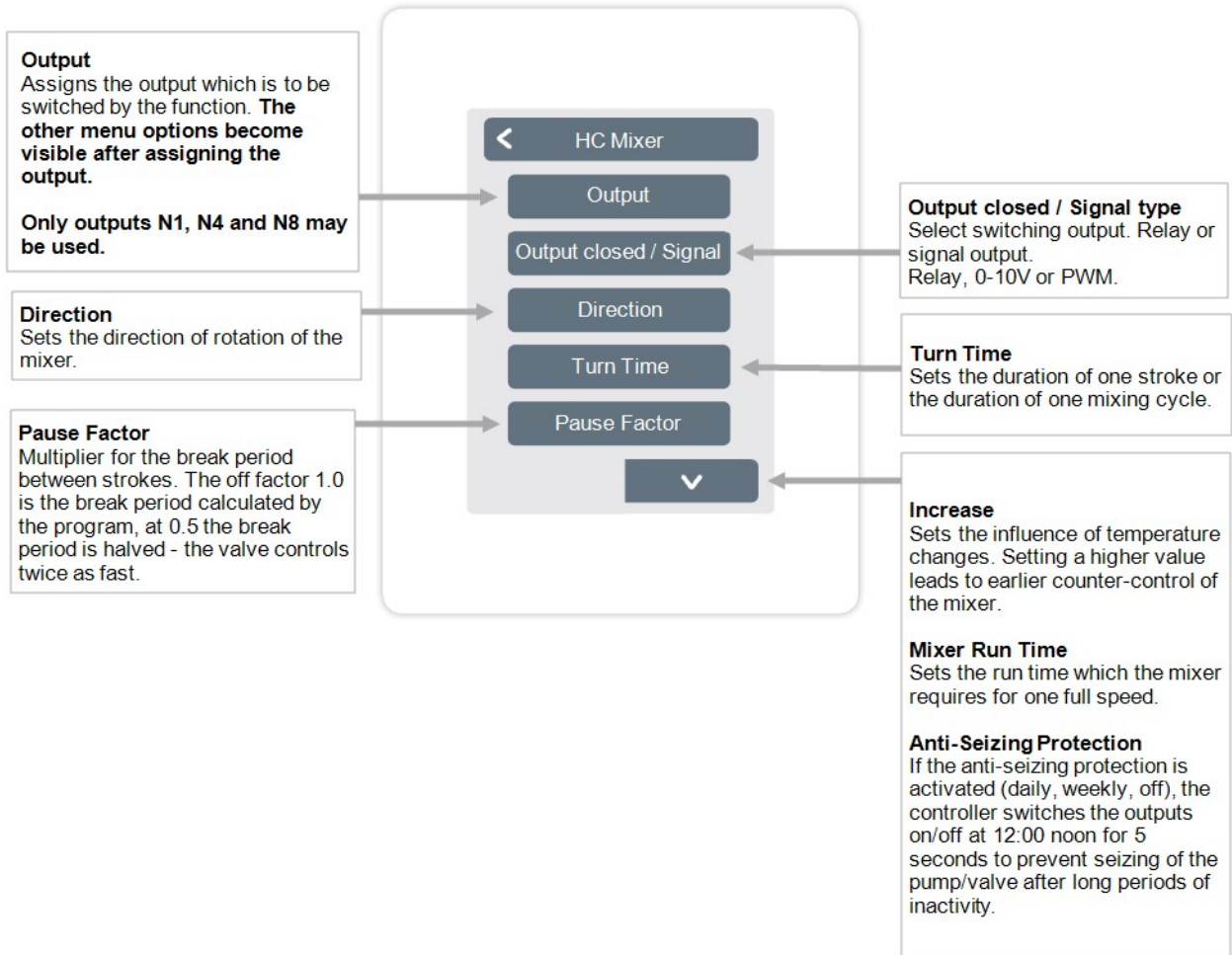

The heating circuit function starts the heating pump at the defined output as soon as at least one zone is active.

**Output**

Assigns the output which is to be switched by the function. **The other menu options become visible after assigning the output.**

By default, the output to the terminal block A of the °CALEONbox is defined here.

**Overrun time**

If all zones are switched off, the pump runs to bring the residual heat into the heating system.

**Insulation factor**

Appears, if 'Outdoor sensor' is defined. Delays the influence of the outdoor temperature on the calculation of the reference flow temperature. 1=poor insulation/ 5 =good insulation.

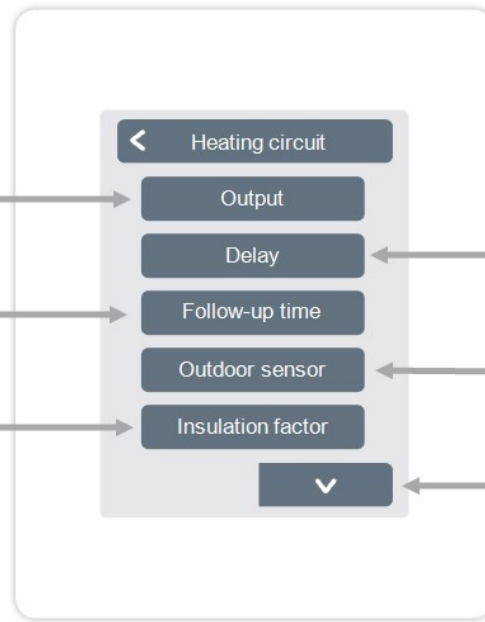

**Delay**

Delays the switching on of the heating circuit pump so that it does not push against closed valves.

**External sensor**

Assignment of the external sensor to control the heating circuit according to the weather.

**Curve Factor**

Appears when "Sensor Outside" is defined. The characteristic curve is used to control the heat dissipation of the heating circuit relative to the outdoor temperature. The characteristic curve can also be changed via parallel shift.

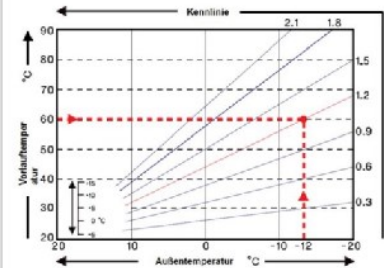

**Parallel shift**

Appears when "Sensor Outside" is defined. A fixed correction value is added to or subtracted from the current reference flow value as calculated by the characteristic curve.

**Room influence**

Influence of the deviation of the reference temperature on the reference flow temperature.

**Flow**

Assignment of the heating circuit flow sensor.

**Min. Flow**

Appears if a sensor is defined for "Flow". Setting the minimum flow temperature.

**Max. Flow**

Appears if a sensor is defined for "Flow". Setting the maximum flow temperature.

**Anti-Seizing Protection**

If the anti-seizing protection is activated (daily, weekly, off), the controller switches the outputs on/off at 12:00 noon for 5 seconds to prevent seizing of the pump/valve after long periods of inactivity.

The difference function switches the defined output as soon as there is a preset temperature difference between the source and target sensor.

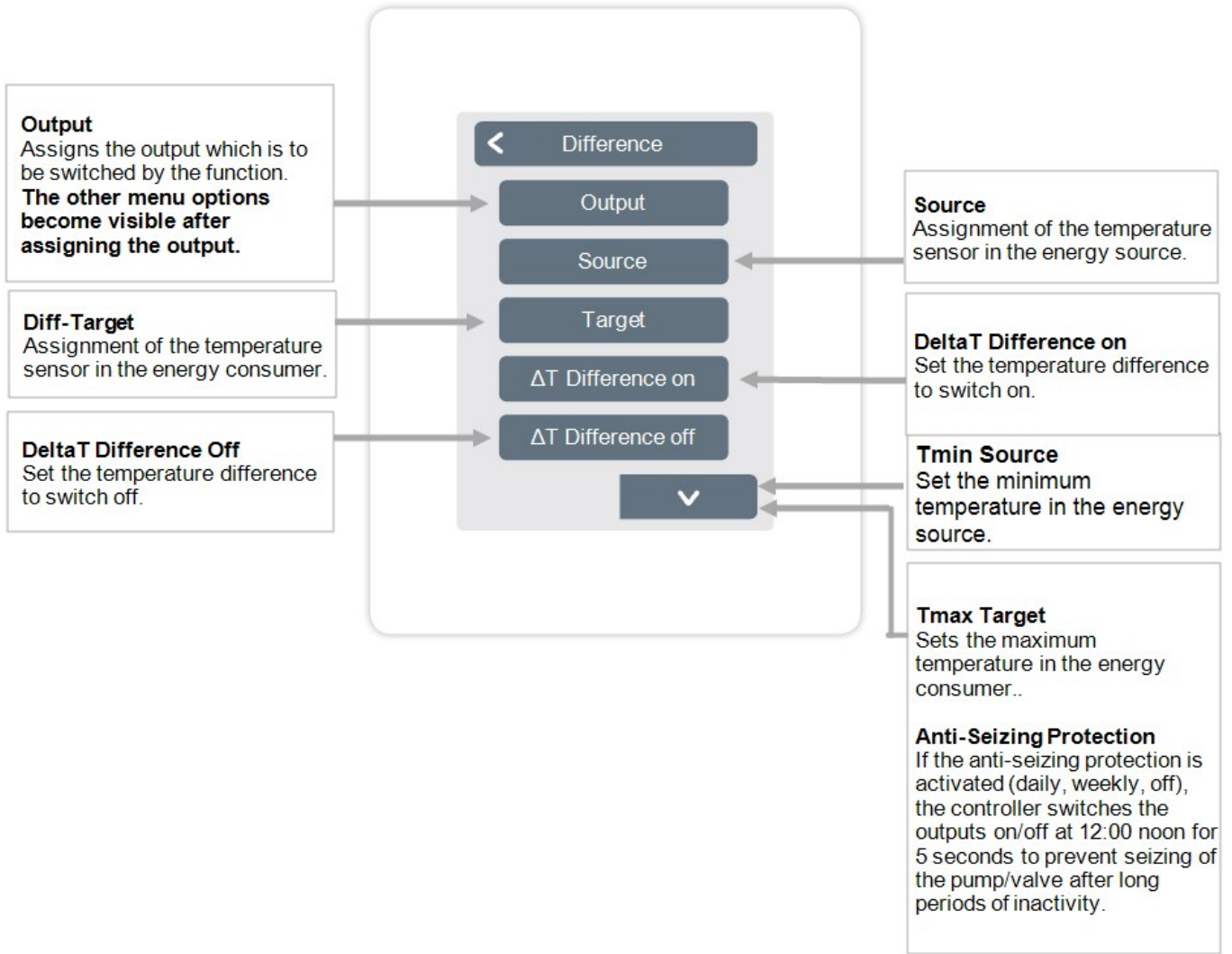

The function Timer 1-2 switches the defined output depending on the set times.

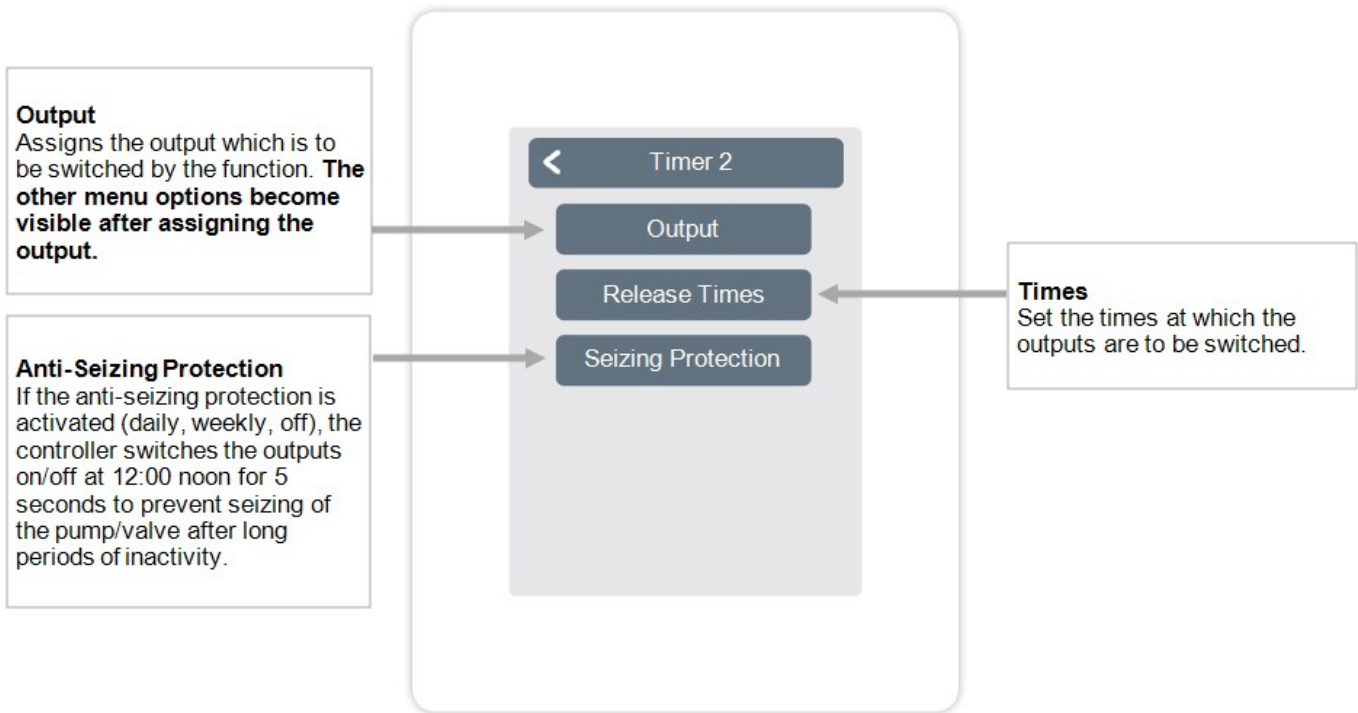

The function energy request switches the defined output when the rooms require energy depending on the set delay.

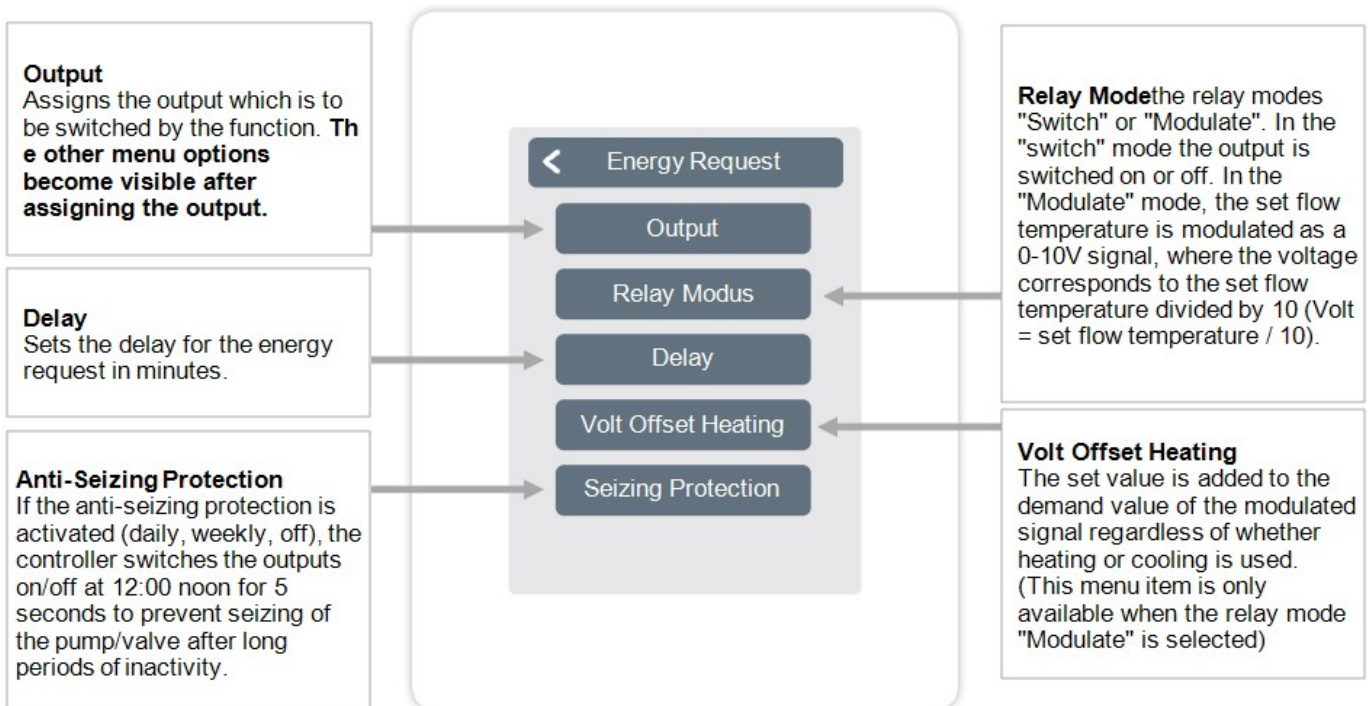

**!** The energy request switches on when energy is required both in heating mode when the set flow rate falls below the set flow rate and in cooling mode when the set flow rate is exceeded. A flow sensor is required for this function.

The fan coil function controls convection heating via the 0-10V/PWM outputs .

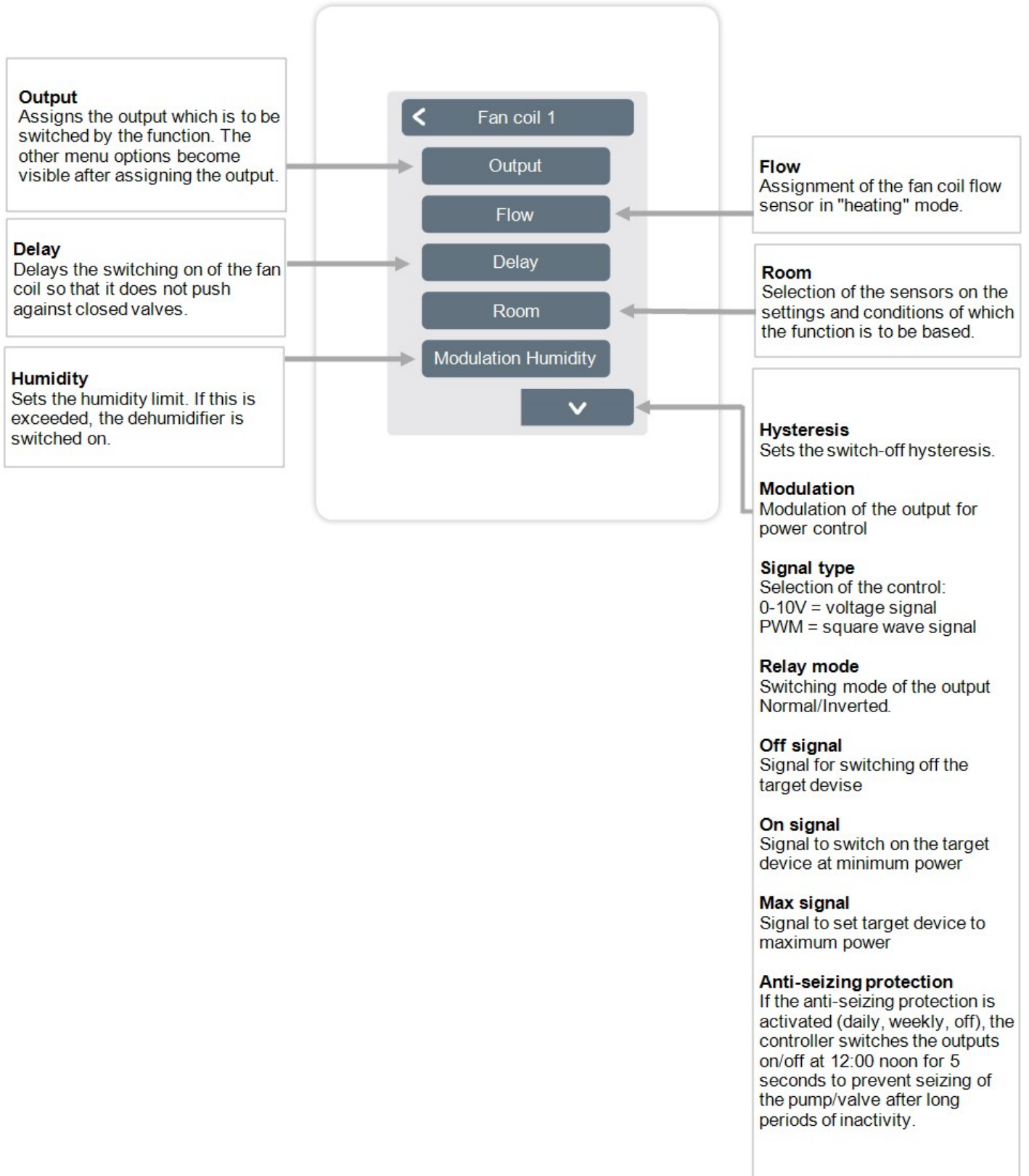

# Zones

verview > Operating mode > Menu > Expert > Settings > Zones

## Zones

Selection of the heating zone to be assigned or managed.

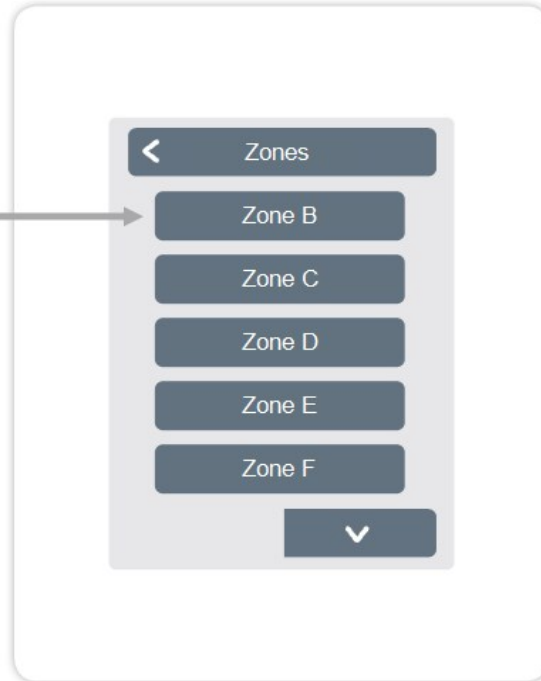

Overview > Operating Mode > Main Menu > Expert > Settings > Zones > Zone B

## Room

Assignment of the rooms in which the zone is located. **First, rooms must be created in the menu under: Expert -> Rooms.**

## S/W Day

Set the temperature limit for summer switch-off in operating mode "Normal" in heating mode.

If the outdoor temperature exceeds this value, this zone is no longer heated.

## Relay mode

Set the switching direction for the zone valves. In normal mode the relay is used as normally open contact, in inverted mode as normally closed contact.

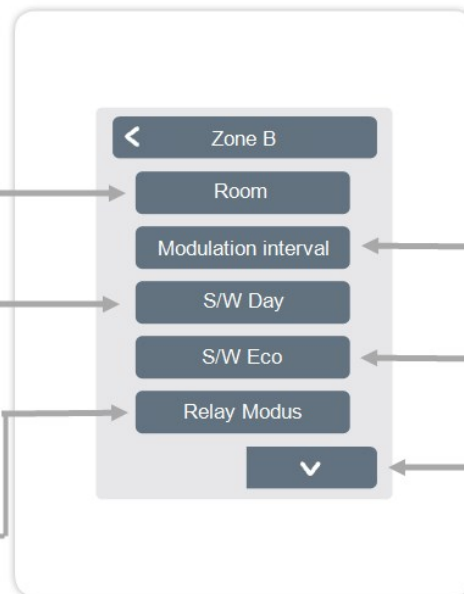

## Modulation period

Provides the option to reduce the overshoot of the room temperature by not continually heating from the time of reaching the reference temperature up until the time of reaching the reference temperature + hysteresis (can be set in the "Room settings" menu). The total length of the period is set in minutes.

## S/W Eco

Set the temperature limit for summer switch-off in operating mode "Eco" in heating mode.

If the outdoor temperature exceeds this value, this zone is no longer heated.

## Floor Sensor

Assignment of the floor sensor.

## Tmax Floor

Sets the maximum temperature of the floor sensor.

## Anti-Seizing Protection

If the anti-seizing protection is activated (daily, weekly, off), the controller switches the outputs on/off at 12:00 noon for 5 seconds to prevent seizing of the pump/valve after long periods of inactivity.

## Example zone setting

**Step 1**  
Please select the appropriate zone.

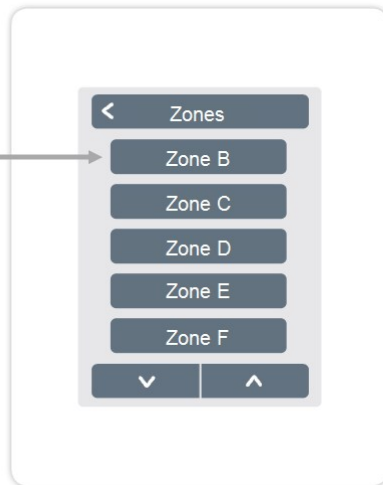

**Step 2**  
Select the room corresponding to the zone.

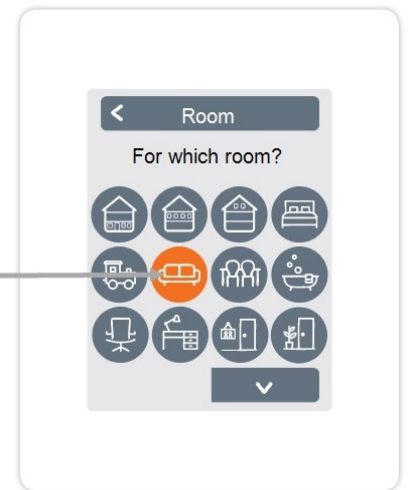

**Step 3**  
Set the desired outdoor switch-off temperature for Regular (S/W Day) mode.

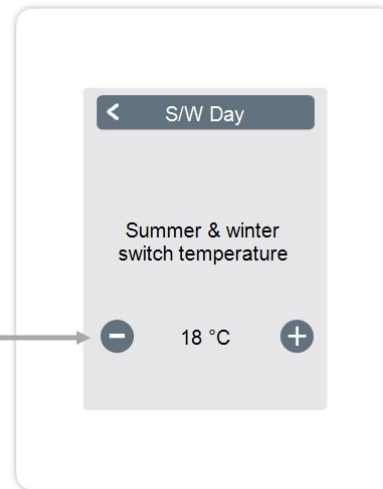

**Step 4**  
Set the desired outdoor switch-off temperature for Eco (S/W Eco) mode.

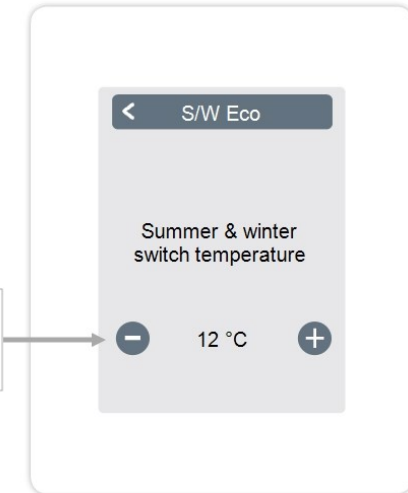

# WiFi

Overview > Operating mode > Menu > Expert > Settings > WiFi



This menu is only present, if a °CALEON Smart or °CALEON Clima Smart is connected.

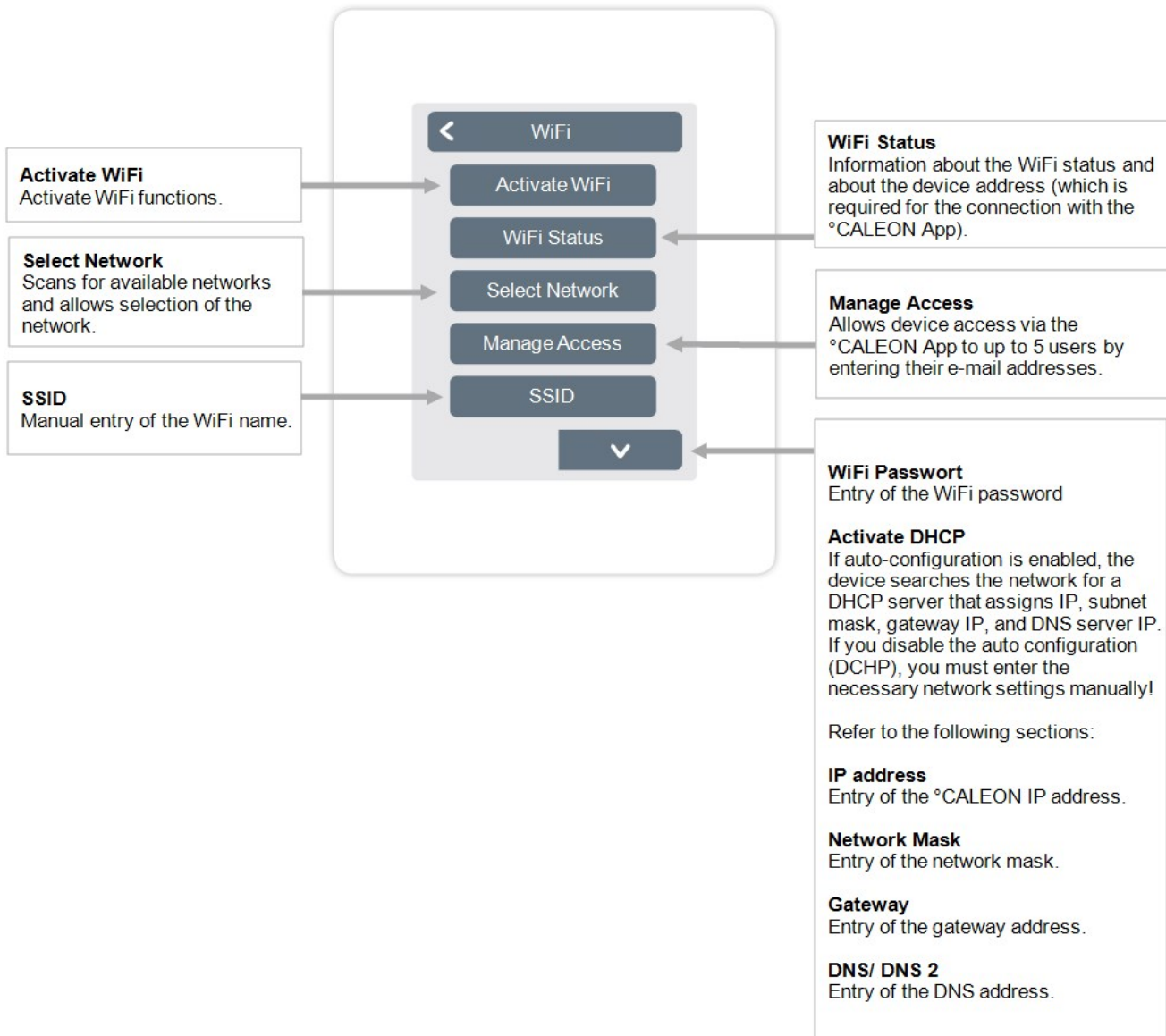





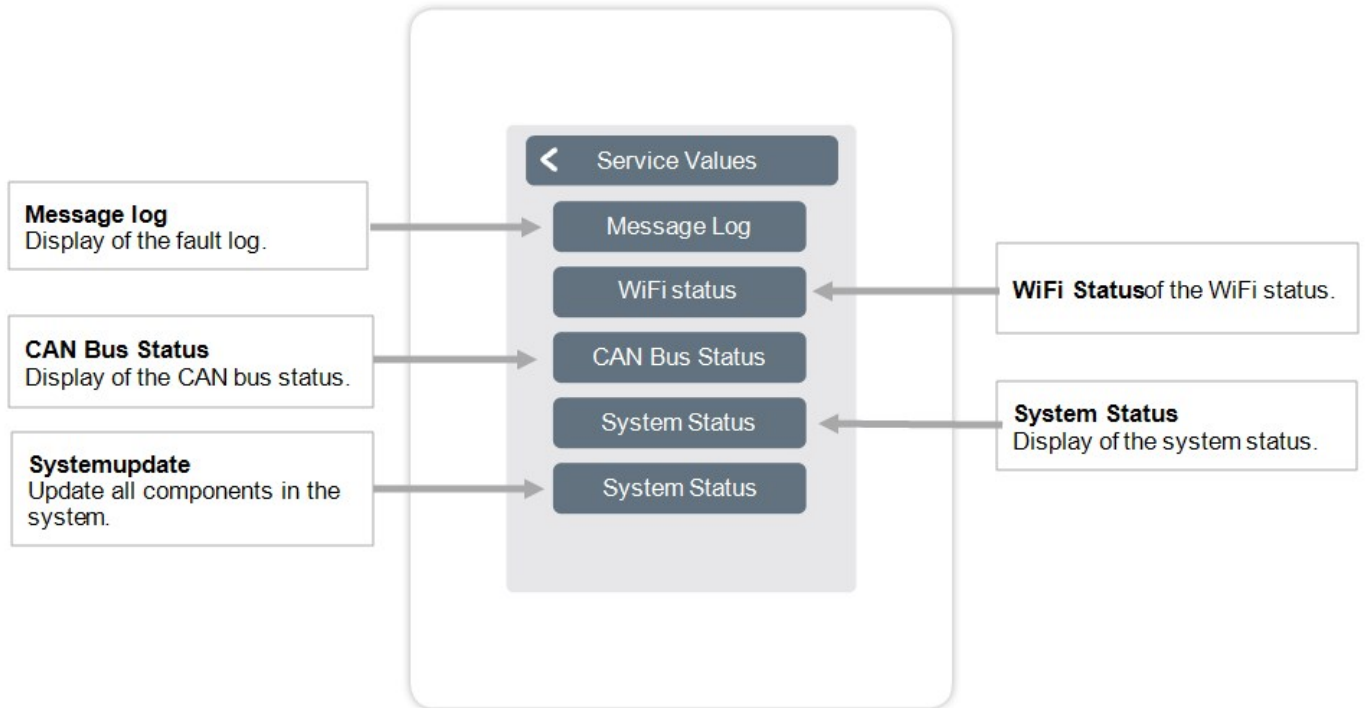

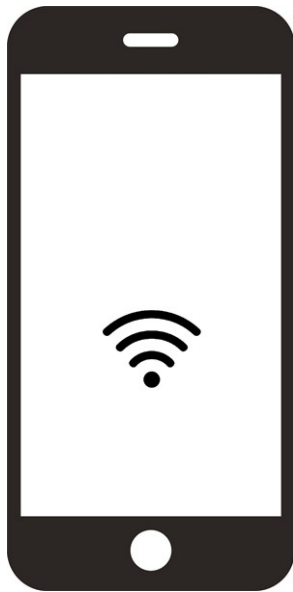

## Service Values

Overview > Operating mode > Menu > Expert > Service values



## °CALEON WiFi and App Configuration



1.  Download °CALEON app to your mobile device. Currently available on Google Play (Android) and Apple App Store (iOS).
2.  Start app and create account.
3.  Click activation link in your e-mail inbox.
4.  Connect °CALEON with the WLAN network:  
Expert → Settings → WiFi → Choose Network
5.  Add selected e-mail address to access list:  
Expert → Settings → WiFi → Access control
6.  Log in to °CALEON app with e-mail and password
- 7.a  If your °CALEON Smart Room Controller is located in the same WiFi network as your mobile device, you can activate it by clicking the "Done! Find °CALEON in WiFi" button.
- 7.b  If the devices are not in the same WiFi network, click the "Enter device address manually" button. The device address is displayed automatically during commissioning or you can find it in the menu under : Expert → Settings → WiFi → WiFi status

## Tips

<b>Interface Mode</b> see "Settings" on page 20	Menu > Expert > Settings > Interface mode Provides the option to restrict the menu against unintentional use, for example, by hotel guests or children.
<b>Download Firmware Updates via WiFi (°CALEON Smart only)</b> see "Devices" on page 21	Provides the option to update °CALEONs and °CALEONboxes in the network to the latest version. °CALEONbox: Menu > Expert > Settings > Devices > °CALEONbox > Firmware °CALEON Room Controller: Menu > Expert > Service Values > Firmware, Download and install update on each °CALEON. It is recommended to check the availability of firmware updates for °CALEON and °CALEONbox before installation.
<b>Insulation factor</b> see "Functions °Cbox" on page 24	Menu > Expert > Settings > Functions °Cbox > Heating Circuit > Insulation factor Provides the option to adapt the flow temperature calculation performed by the controller to the insulation of your building.
<b>Modulation interval</b> see "Zones" on page 30	Menu > Expert > Settings > Zones > Zone B > Modulation interval Provides the option to reduce the overshoot of the room temperature by heating from reaching the target temperature until reaching the target temperature + hysteresis but only for a percentage of the set interval. The total length of the period is set in minutes.
<b>Additional functions</b>	<ol style="list-style-type: none"> <li>1. Menu &gt; Expert &gt; Settings &gt; Functions °Cbox</li> <li>2. Overview of all available additional functions (all °CALEONbox functions are displayed at the °CALEON that configures the °CALEONbox, only local functions of the °CALEON Room Controller are displayed at all other °CALEONs).</li> <li>3. Further setting options for the selected function, see "Functions °Cbox" on page 24.</li> <li>4. Select function and free switching output to activate function.</li> </ol>
<b>°CALEON App (only for °CALEON Smart)</b> see "°CALEON WiFi and App Configuration" on page 33	Provides the option to operate the °CALEON Room cVntroller via app.

**Final Declaration**

Although this list and description have been created with the greatest possible care, incorrect or incomplete information cannot be excluded. Subject as a basic principle to errors and technical changes.

SOREL GmbH Mikroelektronik - Reme-Str. 12 - D - 58300 Wetter (Ruhr) - +49 (0)2335 682 77 0 - +49 (0)2335 682 77 10

-

info@sorel.de - www.sorel.de

26.07.2022